

INSTALLATION

OPERATION

MAINTENANCE

MELLTRONICS DRIVES

MELLTRUM

Series Adjustable DC Drives
5HP to 700 HP

RATINGS

MODEL	HORSEPOWER RATINGS		AC POWER INPUT		DC POWER OUTPUT		FIELD OUTPUT		HEAT LOSS
	240/3/60	480/3/60	VOLTS	MAX AMPS	VOLTS	MAX AMPS	VOLTS	MAX AMPS	MAX WATTS
MELLTRUM 1	5-10HP	5-20HP	240/480	23	240/500	34	150/300	6	117
MELLTRUM 2	15-30HP	25-60HP	240/480	84	240/500	102	150/300	6	367
MELLTRUM 2+	40-50HP	75-100HP	240/480	139	240/500	170	150/300	10	502
MELLTRUM 3	40-60HP	75-125HP	240/480	174	240/500	202	150/300	16	608
MELLTRUM 4	75-125HP	150-250HP	240/480	343	240/500	424	150/300	16	1100
MELLTRUM 4+	150HP	300HP	240/480	402	240/500	480	150/300	16	1300
MELLTRUM 4+4	200HP	400HP	240/480	536	240/500	640	150/300	16	1500
MELLTRUM 5	250-350HP	500-700HP	240/480	940	240/500	1200	150/300	25	3000

Made in the USA by:



MAIL: PO BOX 2368
INDIAN TRAIL, NC 28079-2368
SHIPPING: 3479 GRIBBLE ROAD
MATTHEWS, NC 28104-8114

PHONE: 704-821-6651
www.melltronics.com

SAFETY WARNINGS:

Improper installation or operation of this drive control may cause serious injury to personnel or equipment. Before you begin installation or operation of this equipment you should thoroughly read this instruction manual and any supplementary operating instructions provided. The drive must be installed and grounded in accordance with local and national electrical codes. To reduce potential of electric shock, disconnect all power sources before initiating any maintenance or repairs. Keep fingers and foreign objects away from ventilation and other openings. Keep air passages clear. Potentially lethal voltages exist within the control unit and connections. Use extreme caution during installation and start-up.

BRANCH CIRCUIT PROTECTION:

Branch circuit protection is to be provided by *end user*, if not included.

OVERLOAD PROTECTION:

Since the drive has an electronic overload, no external overload protection is needed per National Electric Code handbook, Article 430-2, Single Motor Applications.

INITIAL CHECKS:

Before installing the drive control, check the unit for physical damage sustained during shipment. Remove all shipping restraints and padding.

INSTALLATION LOCATION OF CONTROL:

Controls are suitable for most factory areas where industrial equipment is installed. The control and operator's control station should be installed in a well-ventilated area. Locations subject to steam vapors or excessive moisture, oil vapors, flammable or combustible vapors, chemical fumes, corrosive gases or liquids, excessive dirt, dust or lint should be avoided unless an appropriate enclosure has been supplied or a clean air supply is provided to the enclosure. The location should be dry and the ambient temperature should not exceed 104°F for an enclosed unit or 131°F for a chassis mount unit. If the mounting location is subject to vibration, the enclosure should be shock-mounted.

If the enclosure has a ventilating fan, avoid, wherever possible, an environment having a high foreign-matter content; otherwise the filters will have to be changed more frequently or micron-filters installed. Should a control enclosure require cleaning on the inside, a low pressure vacuum cleaner is recommended, not an air hose, because of the possible oil vapor in the compressed air and its high pressure.

***MELLTRUM* – RECEIVING INFORMATION**

Please record the following before installing the unit and use these numbers when communication with the factory.

MODEL NAME _____

PART NUMBER _____

SERIAL NO. _____

REVISION _____

MODIFICATIONS _____

ACCEPTANCE:

Carefully inspect shipment upon arrival and check items with packing list. Shortage or damage should be reported promptly to the carrier and your distributor.

TABLE OF CONTENTS

SECTION 1	PERFORMANCE FEATURES	5
1.1	IDENTIFICATION	5
1.2	SPECIFICATIONS.....	5
1.2.1	SERVICE CONDITIONS.....	5
1.2.2	PERFORMANCE SPECIFICATIONS.....	5
1.2.3	ADJUSTMENT RANGES (TYPICAL)	5
1.3	PROTECTION AND PERFORMANCE FEATURES.....	5
1.4	GENERAL DESCRIPTION.....	6
SECTION 2	FUNCTIONAL DESCRIPTION.....	7
2.1	BASIC FUNCTIONAL DESCRIPTION.....	7
2.2	BASIC CIRCUIT ANALYSIS.....	9
2.2.1	ACCEL/DECEL.....	9
2.2.2	VELOCITY ERROR AMPLIFIER.....	10
2.2.3	CURRENT ERROR AMPLIFIER.....	11
2.2.4	TIMING RAMP CIRCUITS	12
2.2.5	COMPARATOR AND GATED OSCILLATOR CIRCUITS.....	12
2.2.6	FAULT TRIP.....	13
2.2.7	CONTROL LOGIC.....	14
SECTION 3	INSTALLATION AND START-UP INSTRUCTIONS	15
3.1	SAFETY WARNINGS	15
3.2	INITIAL CHECKS.....	15
3.3	CONTROL INSTALLATION LOCATION	15
3.4	WIRING	15
3.4.1	POWER WIRING.....	15
3.4.2	RELAY CONTROL WIRING.....	15
3.4.3	SIGNAL WIRING.....	15
3.4.4	FIELD CONNECTIONS.....	16
3.5	PROGRAMMING JUMPERS.....	16
3.5.1	LINE FREQUENCY.....	16
3.5.2	FEEDBACK SOURCE SELECTIONS.....	16
3.5.3	FEEDBACK RANGE JUMPER	16
3.5.4	ARMATURE FEEDBACK.....	16
3.5.5	INPUT VOLTAGE SELECTION.....	16
3.5.6	FIELD LOSS DEFEAT	16
3.5.7	OTHER JUMPERS.....	16
3.6	SHUNT RESISTOR	17
3.7	COOLING FAN VOLTAGE SELECT	18
3.8	CONTACT SUPPRESSION	18
3.9	START-UP PROCEDURES.....	18
3.9.1	POWER OFF CHECKS.....	18
3.9.2	POWER ON CHECKS	18
3.10	ADJUSTMENTS.....	20
SECTION 4	MAINTENANCE AND TROUBLE SHOOTING.....	21
4.1	NORMAL MAINTENANCE	21
4.2	GENERAL TROUBLESHOOTING	21
4.3	SYMPTOMS AND CAUSES	21
4.4	MELLTRUM 1 SCR REPLACEMENT.....	22
4.5	MELLTRUM 2, 2+, 3 , 4 AND 4+ SCR REPLACEMENT	22
SECTION 5	SCHEMATICS	23
SECTION 6	PARTS AND OPTION KITS.....	36
SECTION 7	WARRANTY	39

LIST OF FIGURES

Figure 1: Basic Block Diagram..... 7
 Figure 2: **MELLTRUM** Block Diagram 8
 Figure 3: Accel/Decel Circuit..... 9
 Figure 4: Velocity Error Amplifier 10
 Figure 5: Traces on Scope..... 11
 Figure 6: Current Error Amplifier 11
 Figure 7: Timing Ramp Circuits..... 12
 Figure 8: Comparator and Gated Oscillator Circuits 12
 Figure 9: IFT Circuits Control Logic 13
 Figure 10: Inverse Time Trip Overload Characteristics 14
 Figure 11: Control Logic..... 14
 Figure 12: Two Wire Operation 14
 Figure 13: Shunt Resistor Installation 17
 Figure 14: Suppression Techniques 18
 Figure 15: Test Points at J3 19
 Figure 16: Stability Effects of the Velocity Profile 20
 Figure 17: The Interconnect Board 22
 Figure 18: MC Relay 22
 Figure 19: Dual Package SCR..... 22
 Figure 20: Schematic Diagram - Main Control, Sheet 1 23
 Figure 21: Schematic Diagram - Main Control, Sheet 2 24
 Figure 22: Interconnect Diagram - **MELLTRUM 1** 25
 Figure 23: Option Panel 'A' Interconnect & Customer Connection Diagram – **MELLTRUM 1** 26
 Figure 24: Interconnect Diagram - **MELLTRUM 2 & 2+** 27
 Figure 25: Option Interconnect & Customer Connection Diagram - **MELLTRUM 2**..... 28
 Figure 26: Option Interconnect & Customer Connection Diagram - **MELLTRUM 2+**..... 29
 Figure 27: Interconnect Diagram – **MELLTRUM 3** 30
 Figure 28: Optional Interconnect & Customer Connection Diagram - **MELLTRUM 3** 31
 Figure 29: Interconnect Diagram - **MELLTRUM 4, 4+ AND 4+4** 32
 Figure 30: Option Interconnect & Customer Connection Diagram - **MELLTRUM 4, 4+ AND 4+4**..... 33
 Figure 31: Interconnect Diagram – **MELLTRUM 5** 34
 Figure 32: Interconnect Diagram, Option Kits..... 35

LIST OF TABLES

Table 1: Tachometer Feedback Jumper Setting..... 16
 Table 2: Tachometer Voltage Conversion 16
 Table 3: **MELLTRUM** Shunt Resistor Chart 17

SECTION 1 PERFORMANCE FEATURES

1.1 IDENTIFICATION

It is important that the control unit be identified accurately and completely. The identification tag may be found on the side of the control.

1.2 SPECIFICATIONS

1.2.1 SERVICE CONDITIONS

- Rated Voltage Input:
(203) 240volts (-10.+10%) AC 3phase
(416) 480 volts (-10.+10%) AC 3 phase
- Frequency: 50/60 Hz(±2Hz)
- Ambient Temperature: 0⁰ to 40⁰C (32⁰ - 104⁰F)
- Altitude: Sea Level to 3300 Feet
- Efficiency at Rated Output: Power unit 98% or better depending on selected rating
- Drive System 82% or better depending on selected rating
- Power Factor corrected AC Lines: Drive installation on power factor corrected A.C. Lines should be evaluated by either the local sales office or Manufacture's Field Service Department prior to start-up.

1.2.2 PERFORMANCE SPECIFICATIONS

- Adjustable, Linear Timed Accel/Decel:
2-30 Seconds
- Controlled Speed Range: 20-1
- Current Limit: 0-150%
- Speed Regulation:
(for a 95% Load Change)
Voltage Regulated-2-5%of maximum top speed
Speed Regulated-1%of maximum top speed
(AC or DC Tachometer)
Modified-to 0.1/0.15% of top speed
- ForAllOtherVariables:
Voltage Regulated-Changes of up to 15% of top speed can result from temperature variations, voltage and frequency variations and drift.
Speed Regulated-A.C. tachometer - 2%
Speed Regulated-D.C. tachometer - 1%
- Minimum Speed Adjustment: 0-30% Rated Speed
- Maximum Speed Adjustment: 60-120% Rated Speed
- Overload Capacity: 150% of Rated Current for 1 Minute
- Service Factor: 1.0

1.2.3 ADJUSTMENT RANGES (TYPICAL)

- Minimum Speed: 0 to 30% rated speed
- Maximum Speed: 60 to 120% rated speed
- Acceleration Time: 2 to 30 seconds(linear)
- Deceleration Time: 2 to 30 seconds(linear)
- Jog Speed: 0 to 30% rated speed
- IR Compensation: 0 to 22% rated voltage
- Current Limit: 0 to 150% current

1.3 PROTECTION AND PERFORMANCE FEATURES

Six SCR Full Wave Power Bridge

Provides improved form factor for greater efficiency of operation.

Inner Loop Current Regulator

Inherent high band-width capability for fast response.

SCR Trigger Circuits

Pulse Transformer isolated to withstand 2,400 volts, hard firing high frequency "burst" type pulse train output from individually gated oscillators insure SCR conduction regardless of the effects of line notching on incoming AC power lines. SCR heating during turn-on is also minimized.

AC Line Connectors

Control is insensitive to phase sequencing.

Reactors, Snubber Networks

Prevents interaction and SCR DV/DT failures, due to line "Spikes and Transients". Provides DI/DT protection during SCR turn-on and aids in SCR turn-off during SCR commutation, minimizing the effects of AC power line notching.

DC Overload(Armature)

Senses overcurrent with inverse time trip.

AC Line Filter and Transient Voltage Suppressor Network

Eliminates interaction between the *MELLTRUM* Drive, and other drives or AC equipment.

High Speed Current Limiting SCR Semiconductor Fuses

Provides protection of the SCRs and motor with positive circuit clearing for both AC and DC faults.

Field Loss Protection

Sequences the drive off in the event of loss of motor field current.

Dual Frequency Operation

Basic controls are capable of operating from standard 50/60 Hz power supplies.

Standard Field Adjustments

Maximum speed, minimum speed, jog speed, separate acceleration and deceleration time, stability, current limit, and IR compensation.

Function Indicators

For AC power DC output power, current limit, fault trip, and individual SCR indicators.

Fault Indicating Lights and Protective Circuitry

Provides LED indicators and positive drive shut down for heat sink over temperature, field loss, DC overload and instantaneous over-current.

Test/Reset Push-button

Provides check of fault detection circuitry and LED indicator with button depressed and resets control if fault condition is corrected.

Static Adjustable Current Limit

Allows static setting of desired current limit value without applying AC power and without a connected output load. Current limit indicating light is also supplied to provide visual indication when present current limit is reached.

1.4 GENERAL DESCRIPTION**Main Circuit Board Indicators**

Light emitting diodes (LEDs) on the main circuit board indicate the following:

- AC power on
- DC power on
- Current limit
- DC overload
- Fault trip

In addition to these indicators, there are six LED indicators (one for each SCR) to indicate that each firing circuit is producing pulses.

Fault Trip

The **MELLTRUM** Series control board contains an instantaneous fault trip protection circuit designed to shut the drive down if any of the following occur:

1. Field loss (defeatable).
2. Heat sink over-temperature (except **MELLTRUM** 1)
3. Instantaneous overcurrent (300% of rated).
4. Inverse DC overload (indicated by the DC overload LED)

Test/Reset

If any of the previously stated fault conditions occur, the drive can be reset by depressing the reset button on the main circuit board. The fault light will not reset if the fault is still present.

Control Circuit Board

The **MELLTRUM** Series Drives share a common circuit board. The board is hinged and swings to the left for easy access to the other drive components.

Isolated Control Circuitry

Resistor isolation of the control circuitry from the power buss provides added safety for maintenance personnel, as well as protection for the control in case of a ground fault. The ammeter, speed potentiometer and tachometer are not at line potential.

Current Feedback Isolation

Current transformers on each of the three AC input lines provide isolated armature current information to the main circuit board.

Field Loss Isolation

The field current detection signal is isolated with the use of an opto isolator.

Field Economy

Terminals are provided on the main PC board for use with an externally timed contact for field economy control. On **MELLTRUM** 1 terminals are identified as FE3A and FE3B. On **MELLTRUM** 2, 2+, 3, 4, 4+, 4+4 and 5 terminals are identified as FE1 and FE2. When field economy is not used, terminals should be jumpered.

WARNING

THE SECONDARY OF THE TRANSFORMERS ARE AT LINE POTENTIAL AS WELL AS THE POWER SUPPLY TRANSFORMERS AND ALL CONTROL LOGIC CONNECTIONS ON TB1. THE REMAINING CONTROL CIRCUITRY IS RESISTANCE ISOLATED ONLY AND IS ALSO A SHOCK HAZARD!

Static Adjustable Current Limit

Current limit is adjustable without power applied to the system. The current limit potentiometer is calibrated from 0 to 150% of rated armature current.

A.C.Inputs - Phasing - Frequency

The **MELLTRUM** Series of DC Motor Drives are insensitive to AC line phase sequencing.

Power Supplies

MELLTRUM Drive Controls contain internal 115 VAC, +24 VDC and regulated + 15 VDC, -15 VDC and +10 VDC power supplies. The +10 VDC reference supply is separately regulated to prevent damage to the remaining supplies in case of a speed pot grounding fault.

NOTE

ONLY THE + 10 VDC REFERENCE POWER SUPPLY IS FOR CUSTOMER USE, AND IS INTENDED FOR USE WITH 2K OHM (MINIMUM) SPEED POTENTIOMETER ONLY.

Cooling:

The **MELLTRUM** 1 Drive is designed for adequate heat dissipation throughout its rated horsepower range (assuming that ventilation is not restricted) without the need for cooling fans.

The **MELLTRUM** 2, 2+, 3, 4, 4+, 4+4 and 5 Drives are supplied with a cooling fan. In addition, these models have a thermal switch mounted on the SCR heat sink assembly programmed to sequence the drive off in the event of heat sink over temperature due to fan failure or air flow restriction.

**SECTION 2
FUNCTIONAL DESCRIPTION**

2.1 BASIC FUNCTIONAL DESCRIPTION

An inner current servo loop is combined with a high gain outer velocity servo loop in the **MELLTRUM** DC Drive Series. An advantage of this system is that once a stable current loop is realized, it will limit the current to the DC motor. This will protect the motor, power bridge, and fuses in the event of sudden changes in loading conditions.

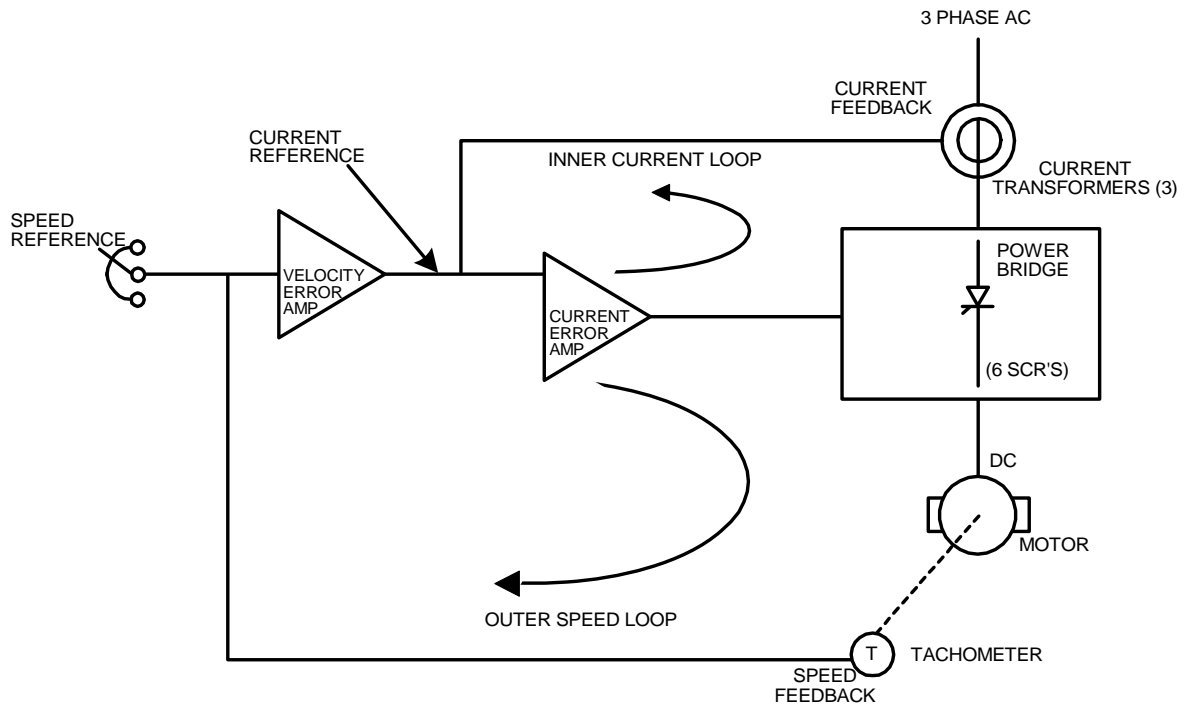

Figure 1: Basic Block Diagram

Inner Current Loop

The inner current loop uses armature current feedback. The armature current is sensed by three current transformers (one for each of three phases) inductively coupled to the incoming line.

The current loop reference (command) is the output of the velocity error amplifier. This command causes an armature current (result) proportional to the command.

Outer Velocity Loop

The outer velocity loop uses voltage (proportional to speed) feedback supplied by a tachometer or by sampling the armature voltage itself. The previously mentioned current loop is contained within its limits until the velocity feedback signal is sufficient to cancel out the reference signal.

Power Converter

A six element, three phase full wave silicon controlled rectifier (SCR) power bridge is used to convert line voltage from AC to DC. The SCR is an electronic switch (thyristor) which is switched on (triggered) at specific phase angles of the incoming AC line, thereby controlling the average DC output voltage to the motor armature. The inner current loop is in total control of this SCR bridge.

Block Diagram

The following block diagram is of a **MELLTRUM** DC Motor Drive. The general flow is explained in the following circuit description.

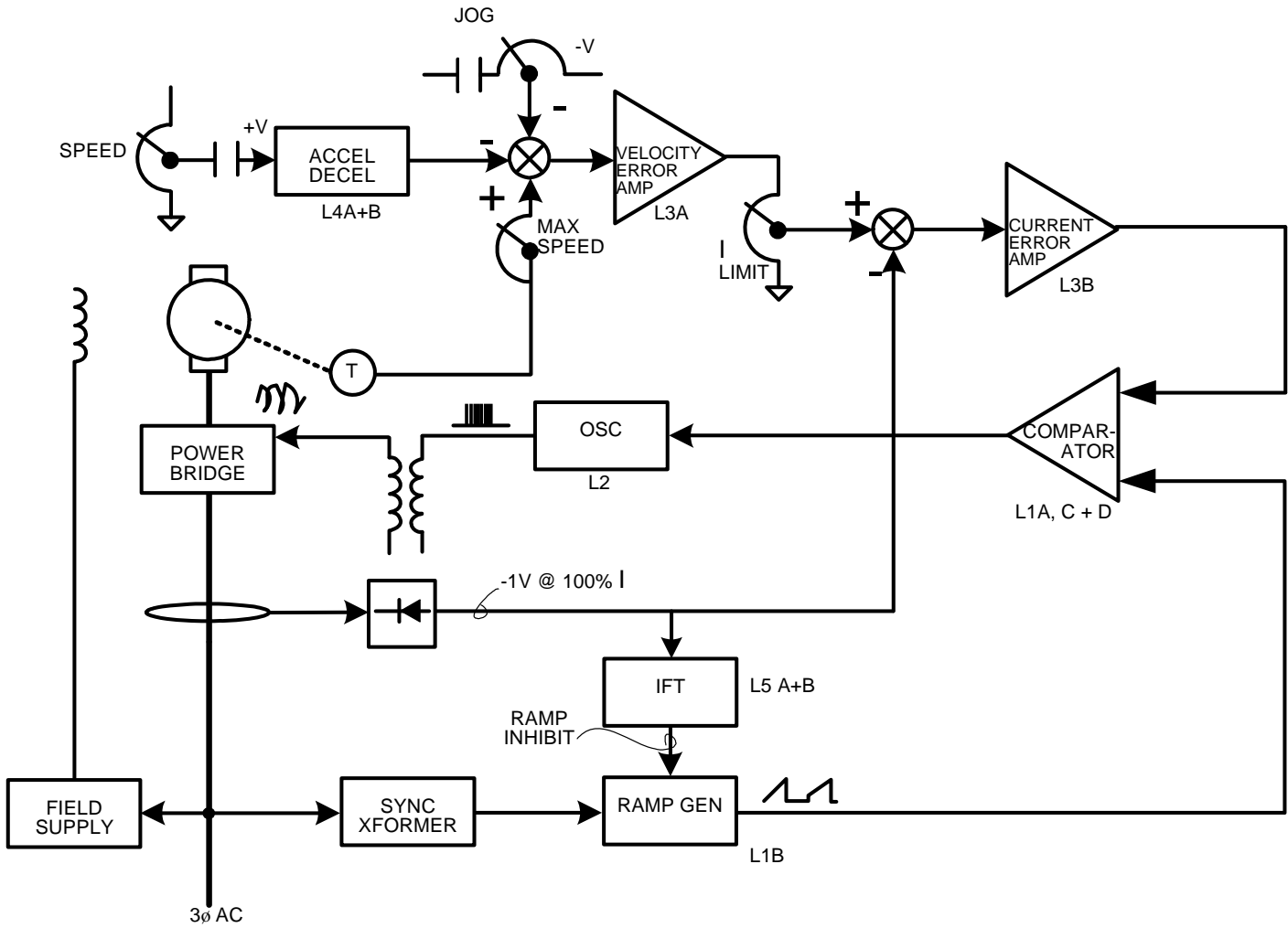

Figure 2: **MELLTRUM** Block Diagram

2.2 BASIC CIRCUIT ANALYSIS

2.2.1 ACCEL/DECEL

When drive run is initiated, an adjustable 0 to +10 V is applied to the accel/decel circuit (L4A and 4B) from the speed potentiometer. The output of this circuit increases linearly in proportion to the amplitude of the input (TB1 terminal 9). The rate of change of the output is determined by the acceleration adjustment setting when the input swings more positive, and the deceleration adjustment when the input swings less positive. The output (TB1 terminal 12) of this circuit is the velocity reference voltage (the polarity being inverted). Clockwise rotation of the corresponding potentiometer increases the acceleration or deceleration time.

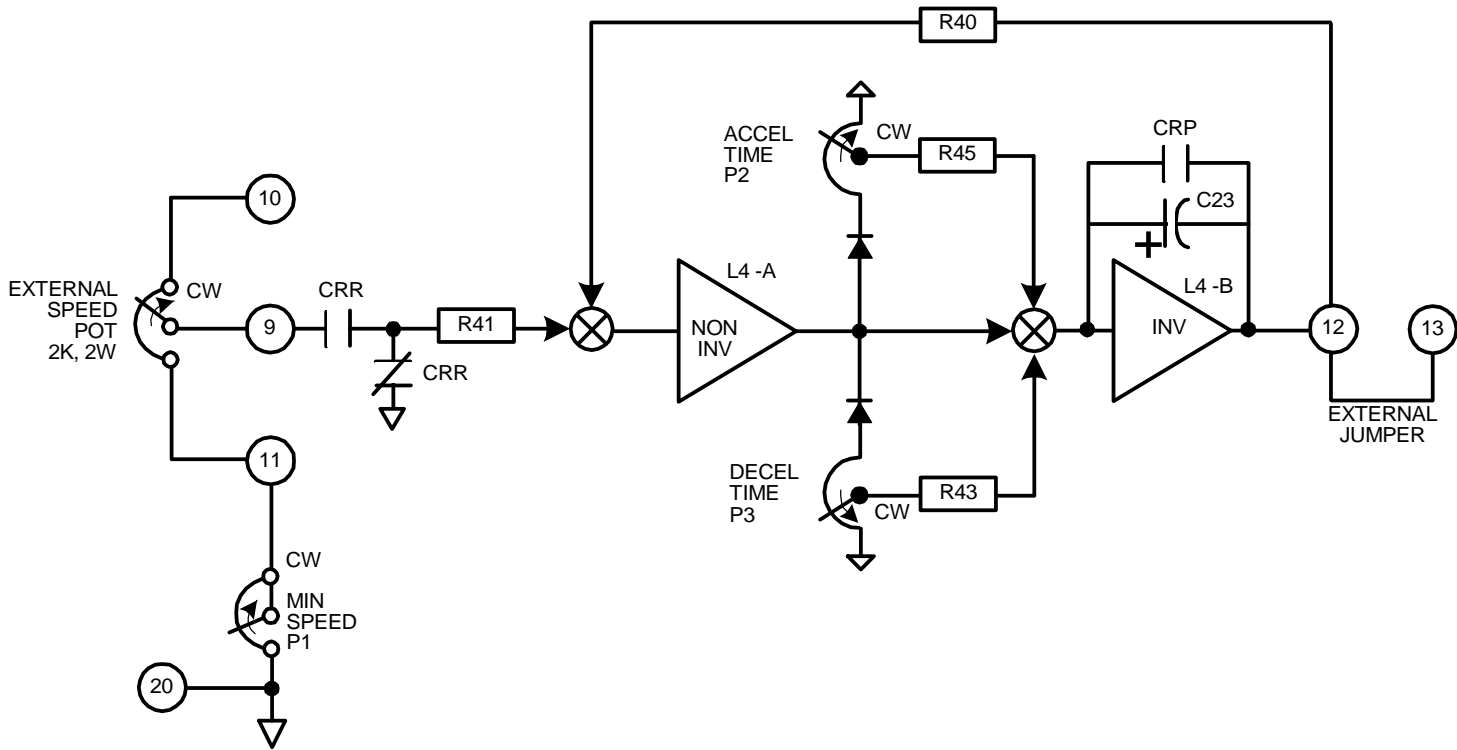

Figure 3: Accel/Decel Circuit

2.2.3 CURRENT ERROR AMPLIFIER

The current error amplifier (L3B) receives a positive voltage from the velocity error amplifier (TB1 terminal 19) and a negative current feedback voltage from the current transformers. The output (L3B pin 7) is a negative voltage with sufficient amplitude to gate the SCR firing circuits on at the required phase angle.

Current limiting is achieved at the input to this amplifier. Potentiometer P7 (current adjust limit) forms a voltage divider which scales the amplitude of the velocity error signal (limiting the current command reference) that reaches the current error amplifier.

A yellow light emitting diode (LED) indicates a current limit condition. When the output of the velocity error amplifier reaches approximately 12 volts, DZ2, a 12 volt zener diode begins to conduct, lighting the LED.

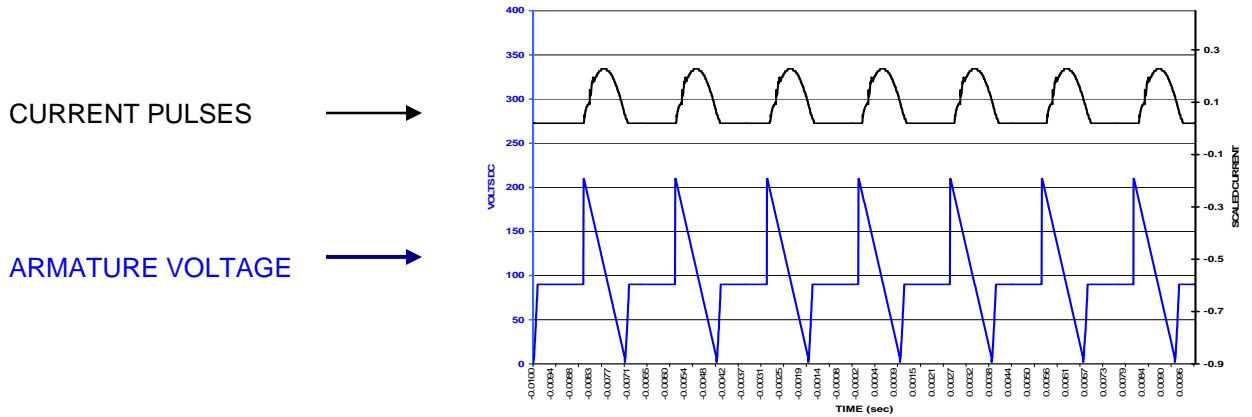

Figure 5: Traces on Scope

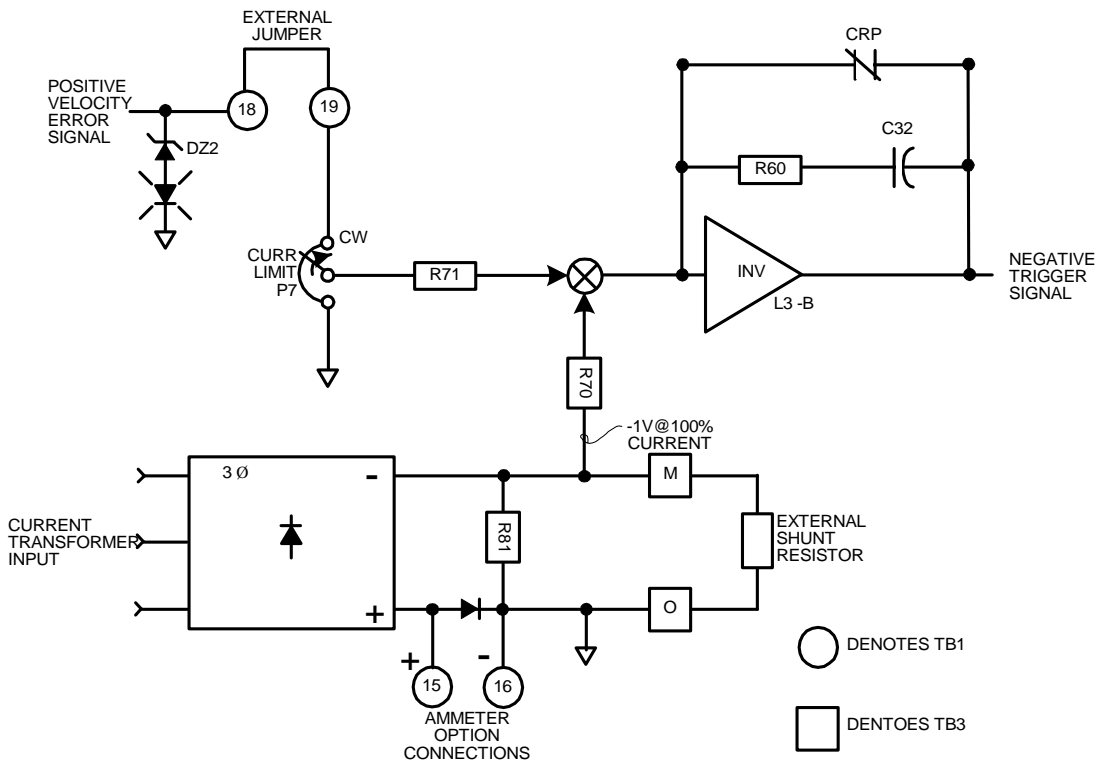

Figure 6: Current Error Amplifier

2.2.4 TIMING RAMP CIRCUITS

An AC line sync signal is supplied to the Q1-L1B switching amplifier combination. The output of L1B is an open collector configuration which removes any charge that may be present on C2, and allows it to charge only while the AC line sync signal to Q1 is a positive voltage. This combination produces a 60 Hz timing ramp. The slope of this timing ramp is determined by P1, R3 and RN1-9. Phase balance adjustment and 50 Hz compensation is achieved by adjusting the charge rate of capacitor C2. There are six timing ramp circuits followed by six comparator-oscillator circuits (one for each SCR).

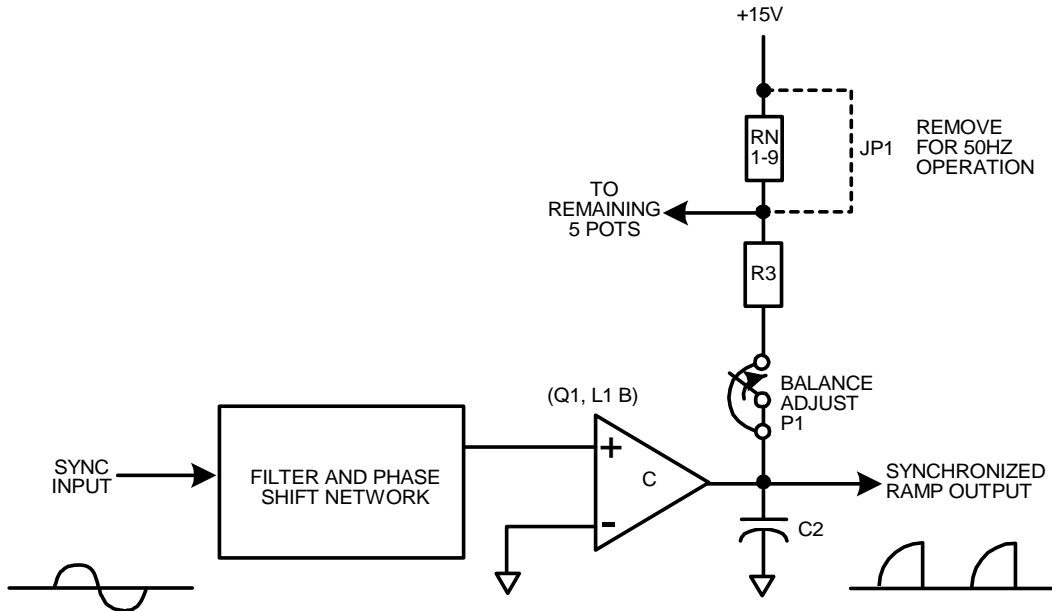

Figure 7: Timing Ramp Circuits

2.2.5 COMPARATOR AND GATED OSCILLATOR CIRCUITS

L1C is a voltage comparator that has a threshold voltage level controlled by the negative trigger signal of the current error amplifier. When the voltage level of the timing ramp exceeds the threshold voltage level of the comparator gate, the output of L1C toggles to OV causing L1A to toggle positive. This signal enables the gated oscillator L2. The gated pulse train output of L2 is then sent to the SCRs through the isolator pulse transformer, T6. Each of the six trigger circuits receives a 60° displaced synchronizing signal. This results in six current pulses to the motor per line cycle.

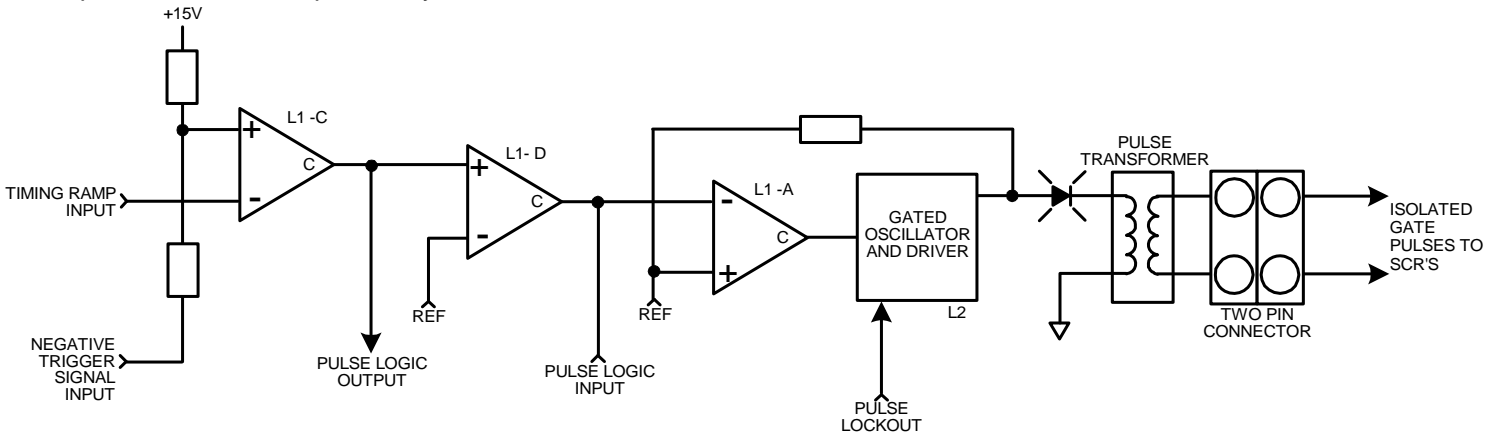

Figure 8: Comparator and Gated Oscillator Circuits

2.2.6 FAULT TRIP

The **MELLTRUM** fault trip circuit is designed to protect equipment in response to:

1. Field loss.
2. Heat sink over-temperature (except **MELLTRUM 1**) Instantaneous over-current (300% of rated).
3. Inverse time DC overload.
4. Phase loss or current imbalance.

If any of the above conditions occur, Q6 is turned off, de-energizing control relay CRFT. This sequences the drive control off. In this condition, the lockout inputs to the gate circuits are pulled low, preventing SCR firing. Field loss, heat sink over-temperature, and instantaneous over-current protection are achieved by turning Q8 off (which is normally biased on), triggering SCR 2.

The DC overload circuit contains two operational amplifiers, an integrator (L5A), and (L5B) a comparator. When the armature current exceeds its rated limit (or a current feedback voltage greater than 1 volt), the integrator starts to ramp positive (the rate of rise being proportional to the amount of over-current). When the integrator ramps to approximately + 10 volts, the comparator will swing positive and trigger SCR 1. This circuit allows the control to be in 150% current limit for approximately one minute, then sequences the drive off. The reset will be disabled for approximately one minute.

NOTE

FIELD LOSS PROTECTION MAY BE DISABLED BY JUMPERING TERMINALS "O" AND "N" AT TB3. REFER TO START-UP PROCEDURES.

Phase loss is detected by Q5; and L6 which is also a current balance monitor. Severe current pulse imbalance will shut the drive down.

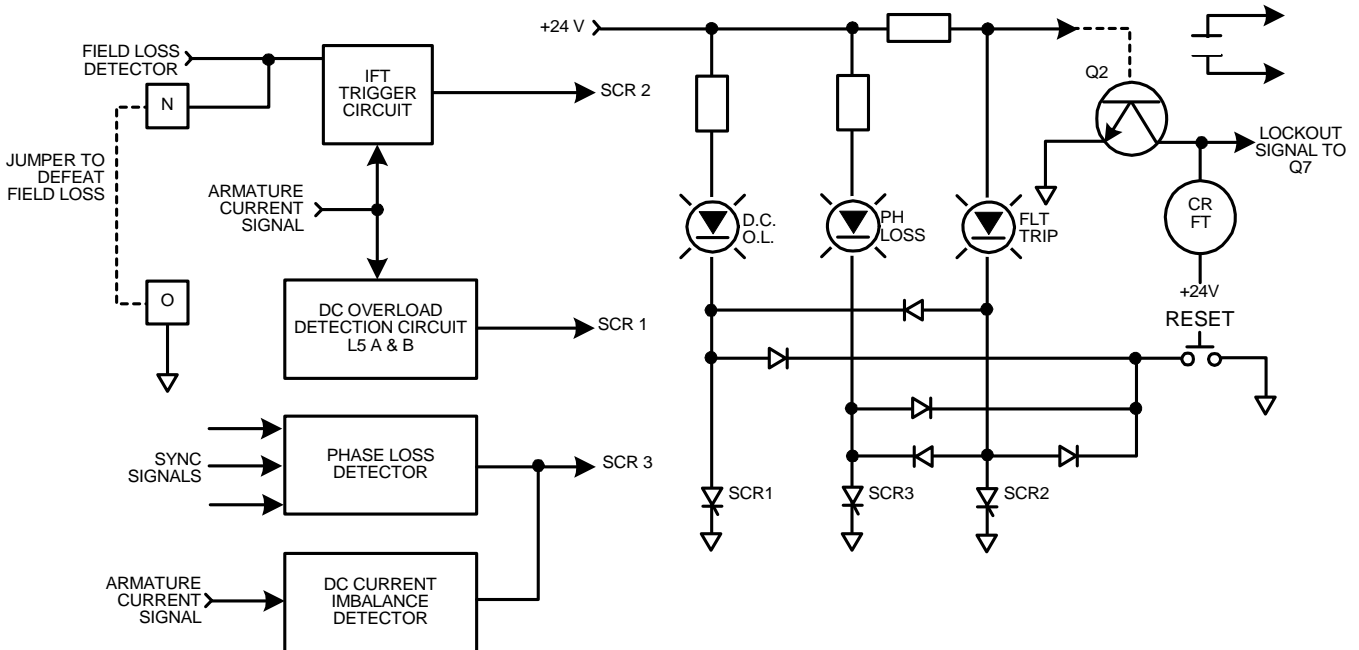

Figure 9: IFT Circuits Control Logic

2.2.7 CONTROL LOGIC

Momentary contact, 115 VAC if the push-button switches are used to sequence the drive on and off. The 115 VAC control voltage is converted to 73 volts or 24 volts DC to operate the control relays. A typical run sequence follows:

The run push-button is depressed making a momentary closure between terminals #5 and #6 of TB1. This energizes CRR and is interlocked "ON" via one of its normally open (NO) contacts. Concurrently, another "NO" contact of CRR closes and supplies 115 VAC to the coil of the armature contactor control relay MC. This in turn will cause a "NO" contact of MC to close and is to be used by the customer to energize an external DC loop contactor. A "NO" contact of this contactor is then returned to terminals #2 and #3 of TB1, that, when closed, (when the DC loop contactor is closed) energizes control relay CRP. CRP then releases the clamp on the velocity and current error amplifiers. CRP also enables the field loss detection circuit. A typical jog sequence would be the same as the run sequence except that a momentary closure is made between terminals #4 and #6 of TB1 and that CRJ is not interlocked "ON" (CRJ is de-energized when closure between #2 and #3 is opened). Please note, jog cannot be energized in a run mode (although a run command will override a jog condition).

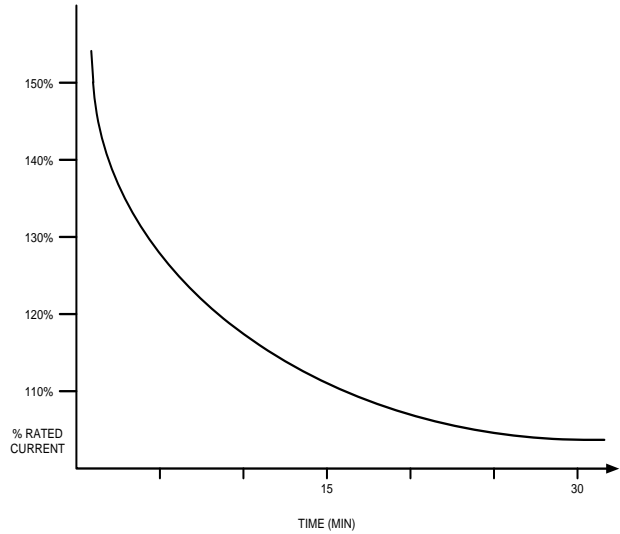

Figure 10: Inverse Time Trip Overload Characteristics

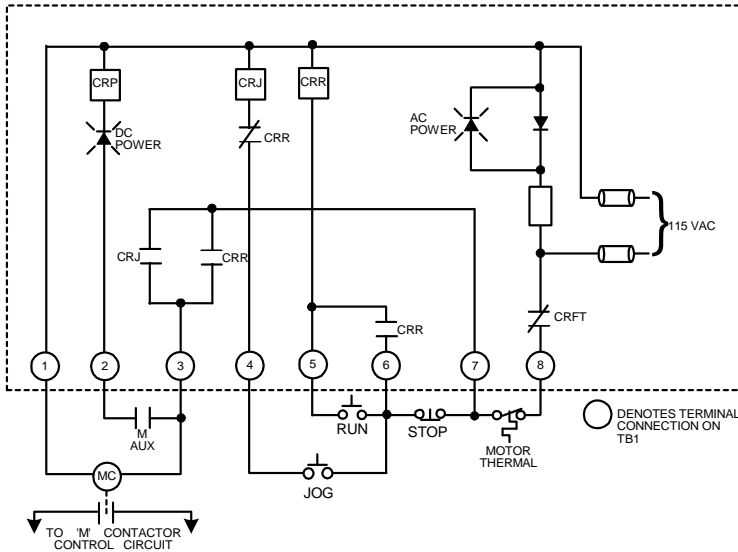

Figure 11: Control Logic

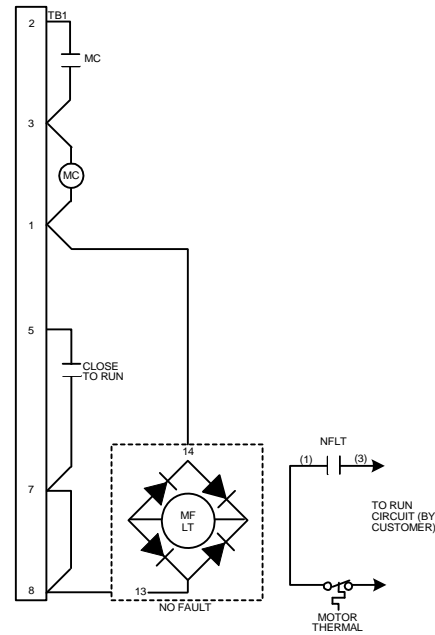

Figure 12: Two Wire Operation

NOTE

WHEN TWO WIRE OPERATION IS USED, THE "NO FAULT" CONTACT PROVIDED BY NFLT RELAY AND THE MOTOR THERMAL SWITCH SHOULD BE WIRED INTO THE SYSTEM PROVIDING THE RUN CONTACT SO THAT RESETTING THE FAULT IN THE DRIVE CANNOT CAUSE A DRIVE START. THE MOTOR THERMAL SHOULD ALSO BE WIRED INTO THE SYSTEM PROVIDING THE RUN CONTACT SO THAT MOTOR COOLING WILL NOT CAUSE A RESTART. WHEN POSSIBLE, THE MACHINE OPERATOR SHOULD BE THE ONE TO INITIATE DRIVE STARTS.

SECTION 3 INSTALLATION AND START-UP INSTRUCTIONS

3.1 SAFETY WARNINGS

Improper installation or operation of this drive control may cause serious injury to personnel or equipment. Before you begin installation or operation of this equipment **you should** thoroughly read this instruction manual and any supplementary operating instructions provided. The drive must be installed and grounded in accordance with local and national electric codes. To reduce potential of electric shock, disconnect all power sources before initiating any maintenance or repairs. Keep fingers and foreign objects away from ventilation and other openings. Keep air passages clear. Potentially lethal voltages exist within the control unit and connections. Use extreme caution during installation and start-up.

3.2 INITIAL CHECKS

Before installing the drive control, check the unit for physical damage sustained during shipment. Remove all shipping restraints and padding.

3.3 CONTROL INSTALLATION LOCATION

Controls are suitable for most factory areas where industrial equipment is installed. The control and operator's control station should be installed in a well ventilated area. Locations subject to steam vapors or excessive moisture, oil vapors, flammable or combustible vapors, chemical fumes, corrosive gases or liquids, excessive dirt, dust or lint should be avoided unless an appropriate enclosure has been supplied or a clean air supply is provided to the enclosure. The location should be dry and the ambient temperature should not exceed 131°F for chassis mount or 104°F for an enclosed unit. If the mounting location is subject to vibration, the unit should be shock mounted.

If the enclosure has a ventilating fan, avoid, wherever possible, an environment having a high foreign-matter content; otherwise the filters will have to be changed more frequently or micron-filters installed. Should a controller enclosure require cleaning on the inside, a low pressure vacuum cleaner is recommended, not an air hose, because of the possible oil vapor in the compressed air and its high pressure.

3.4 WIRING

3.4.1 POWER WIRING

The **MELLTRUM** will operate from typical AC power lines. The line should be monitored with an oscilloscope to insure that transients do not exceed limitations as listed below:

1. Repetitive line spikes of less than 10 microseconds must not exceed the following magnitude:
 - 240 Volts - 400 Volt Peak
 - 380 Volts - 632 Volt Peak
 - 480 Volts - 800 Volt Peak

2. Non-repetitive transients must not exceed 25 watt seconds of energy. Transients of excessive magnitude or time duration can damage DV/DT networks or surge suppressors.
3. Line notches must not exceed 300 microseconds in duration. An abnormal line condition can reflect itself as an intermittent power unit fault. Power unit failure may result from high amplitude spikes or excessive notch conditions in the applied power.

The **MELLTRUM** Drive Control is not sensitive to AC line phase sequencing.

Connect power lines as outlined by local and national electrical codes to the threaded studs supplied for line and armature connections and recommended lug and wire sizes.

WARNING

AN ARMATURE CONTRACTOR IS MANDATORY. USE OF THIS CONTROL WITHOUT AN ARMATURE CONTRACTOR VOIDS ALL WARRANTY AND RESPONSIBILITY OF MANUFACTURE STATED OR IMPLIED. IF A CUSTOMER SUPPLIED ARMATURE CONTRACTOR IS USED, IT IS IMPORTANT THAT ITS AUXILIARY CONTACTS MAKE AFTER ITS POWER CONTACTS, AND BREAK BEFORE ITS POWER CONTACTS.

When wiring the armature contactor to the MC (Main Contactor Control Relay), use the contacts labeled "NORMALLY OPEN".

3.4.2 RELAY CONTROL WIRING

The first eight terminals of TB1 are used for control logic wiring. Refer to the wiring diagram found in the addendum for typical connections.

3.4.3 SIGNAL WIRING

Terminals 9 through 22 of TB1 accept all signal wiring connectors. It is recommended that shielded wire be used for reference (speed potentiometer) and tachometer connections (optional ammeter connections should also incorporate shielded wire). Belden #83394 (two conductor) and Belden #83395 (three conductor shielded cable) or equivalent. The shields should be taped off at the remote end and connected to common, TB1 terminal 20, at the DC drive. Wiring should also be routed away from high current lines (i.e., AC line and armature wiring).

CAUTION

AT NO POINT SHOULD ANY CONNECTION BE MADE TO EARTH GROUND UNLESS SPECIFICALLY SHOWN ON SYSTEM DIAGRAMS.

3.4.4 FIELD CONNECTIONS

Maintain proper polarity when making field connections (F1 to F+).

The **MELLTRUM** Field Supply supplies 150 VDC when connected to a 230 VAC line or 300 VDC when wired to a 460 VAC line. Field connections are made to a separate terminal strip located near the line fuses. Field economy requires a sequencing contact wired to the FE1/2 terminals. If not used, these terminals must be jumpered.

NOTE

THE CONNECTIONS SHOWN IN THIS MANUAL WILL CAUSE THE MOTOR TO ROTATE COUNTER-CLOCKWISE (WHEN FACING THE COMMUTATOR END). TO REVERSE MOTOR ROTATION, REVERSE THE ARMATURE CONNECTIONS (A1 AND A2) AT THE MOTOR. DO NOT REVERSE THE SERIES OR SHUNT FIELD POLARITY.

3.5 PROGRAMMING JUMPERS

All **MELLTRUM** Controls when shipped are programmed for:

60 Hz 460VAC Armature Feedback

A description of jumpers follows. Be sure all program jumpers are correct for your installation.

WARNING

EQUIPMENT DAMAGE AND/OR PERSONAL INJURY MAY RESULT IF ANY JUMPER PROGRAMMING IS ATTEMPTED WHILE THE **MELLTRUM IS OPERATIONAL. LOCK OUT POWER AT THE DISCONNECT BEFORE CHANGING ANY JUMPER POSITIONS.**

3.5.1 LINE FREQUENCY

JP1 is located on the right hand side of the board, near the "IR" comp potentiometer. Cut this jumper for 50 Hz operation.

3.5.2 FEEDBACK SOURCE SELECTIONS

Located on TB3. Selects armature or tachometer feedback. Jumper "F" to "G" for tachometer feedback. For Armature feedback jumper H1-H2.

3.5.3 FEEDBACK RANGE JUMPER

Selects the acceptable range of feedback voltage levels.

Table 1: Tachometer Feedback Jumper Setting

TACH VOLTAGE AT MAX SPEED	JUMPER CONNECTION
40 TO 160	LOW
70 TO 250	MED
130 TO 250	HIGH

NOTE

AC TACHOMETER GENERATORS ARE COMMONLY NAMEPLATED IN VAC (RMS)/1000 RPM. THIS AC VOLTAGE MUST BE CONVERTED TO A DC VALUE. THIS REQUIRES A DIODE BRIDGE AND FILTER NETWORK WHICH IS INCLUDED IN THE DRIVE REGULATOR CIRCUITRY. SINCE THE OUTPUT WAVE FORM OF AN AC TACHOMETER VARIES SOMEWHAT DUE TO NON-SINUSIDUAL CHARACTERISTICS, THE FOLLOWING TABLE SHOULD BE USED TO CALCULATE THE DC VOLTAGE PRODUCED IN THE DRIVE REGULATOR CIRCUITRY.

Table 2: Tachometer Voltage Conversion

AC TACHOMETER	VAC/ 1000RPM	VDC/ 1000RPM
3111 TYPE	45/90	62/126
AN TYPE	45/90	50/100
RE TYPE	45/90	50/100

3.5.4 ARMATURE FEEDBACK

The maximum speed pot controls the armature feedback range. The armature feedback range is 150-600 V @ 10 V ref input.

NOTE

IF A FIELD WEAKENING UNIT IS USED WITH THE **MELLTRUM DRIVE, TACHOMETER FEEDBACK IS NECESSARY. TO DETERMINE THE TACHOMETER VOLTAGE AT MAXIMUM SPEED, USE THE FOLLOWING FORMULA:**

$$\frac{\text{MAXIMUM TACHOMETER SPEED (RPM)}}{1000} \times \frac{\text{VOLTS PER 1000 RPM}}{\text{TACH RATING}} = \frac{\text{MAXIMUM TACHOMETER VOLTAGE}}{\text{VOLTAGE}}$$

3.5.5 INPUT VOLTAGE SELECTION

Located at TB2. Jumper "B" to "C" and "C" to "D" for 460 VAC operation or "A" to "B" and "D" to "E" for 230 VAC operation.

3.5.6 FIELD LOSS DEFEAT

Jumpering terminals "O" and "N" at TB3 disables field loss protection (install this jumper only if an external field supply is used).

3.5.7 OTHER JUMPERS

TB1 terminal numbers 12 to 13 interconnects the accel/decel circuit to the velocity error amplifier. TB1 terminal numbers 18 to 19 interconnect the velocity error amplifier to the current error amplifier. These jumpers allow additional flexibility to the **MELLTRUM** Series and should be in place when using the control as a standard speed control.

3.6 SHUNT RESISTOR

It is necessary to match the **MELLTRUM** Drive to a given motor. Use the charts below to determine the part number of the required shunt. Install this resistor between terminals "O" and "M" at TB3.

Table 3: **MELLTRUM** Shunt Resistor Chart

UNIT	480 VAC	240 VAC	SHUNT (3 watt)	
	500 VDC	240 VDC	PART NUMBER	RESISTANCE (ohms)
	HP	HP		
MELLTRUM 1	5	N/A	NOT REQUIRED	NOT REQUIRED
	7.5	N/A	222-001	8.90
	10	5	222-003	4.71
	15	7.5	222-004	2.39
	20	10	222-007	1.57
MELLTRUM 2	25	N/A	222-009	7.06
	30	15	222-003	4.71
	40	20	222-008	2.83
	50	25	222-005	2.02
	60	30	222-007	1.57
MELLTRUM 2+	75	40	222-004	2.39
	100	50	222-007	1.57
MELLTRUM 3	75	40	222-008	2.83
	100	50	222-006	2.14
	125	60	222-007	1.57
MELLTRUM 4	125	60	222-003	4.71
	150	75	222-002	3.36
	200	100	222-006	2.14
	250	125	222-007	1.57
MELLTRUM 4+	300	150	222-000	1.00
MELLTRUM 4+4	400	200	222-000	1.00
MELLTRUM 5	500	250	222-008	2.83
	600	300	222-006	2.14
	700	350	222-007	1.57

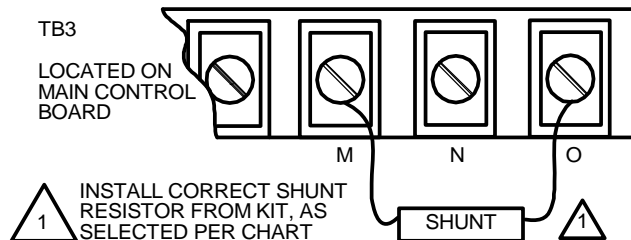

Figure 13: Shunt Resistor Installation

NOTE
THESE RESISTORS ARE SUPPLIED WITH THE **MELLTRUM** DC DRIVE UNIT.

3.7 COOLING FAN VOLTAGE SELECT
(Excludes *MELLTRUM* 1)

Located at the bottom of the chassis on the interconnect board (TB4)

MELLTRUM 2, 2+, 3 and 5

For 230 VAC Operation

Jumper "A" to "B" & "D" to "E"

For 460 VAC Operation

Jumper "B" to "C" & "C" to "D"

MELLTRUM 4, 4+ and 4+4

For 230 VAC Operation

Jumper "A" to "B" & "C" to "D"

For 460 VAC Operation

Jumper "B" to "C"

3.8 CONTACT SUPPRESSION

To reduce the possibility of electrical noise interference all relays or electrical solenoids with wiring in close proximity to the *MELLTRUM* Control wiring should be properly suppressed. Note that it is generally not necessary to suppress non-inductive loads such as resistive heater elements.

Such suppression, as shown in the following figures, also reduces contact arcing and increases contact life.

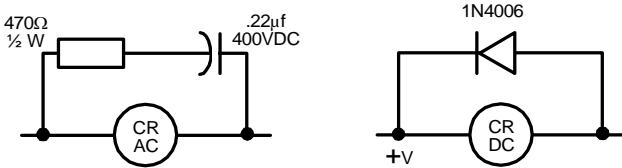

Figure 14: Suppression Techniques

3.9 START-UP PROCEDURES

CAUTION

THE FOLLOWING START-UP INSTRUCTIONS ARE INTENDED ONLY AS A GUIDE, AND SHOULD BE CLEARLY UNDERSTOOD BY THE RESPONSIBLE INSTALLATION PERSON BEFORE PROCEEDING WITH THEM.

3.9.1 POWER OFF CHECKS

Prior to applying power, make a detailed visual inspection of the system, checking for:

- Loose electrical connections
- Pinched wires at the control, motor, or operator's station.
- Loose mechanical connections, especially the tachometer coupling.
- Mechanical binding.
- Incorrect power transformer connections.
- Metallic chips within the drive caused by drilling into the enclosure.
- Correct jumper programming.
- Check the resistance to ground from the armature, the field, and the system common (TB1 terminal #20). If a resistance of 1 megohm or less is measured, clear the short or partial short before applying power.

3.9.2 POWER ON CHECKS

Apply AC power and make the following checks:

- Check for air flow from the blower fan (if so equipped)
- Check AC and DC supply voltages (test points available at J3. Refer to Figure 15 or use the optional test meter.)
- Note the level of the current limit setting.

Turn min. speed adjustment fully counter-clockwise. With the speed potentiometer fully counter-clockwise, press the start speed potentiometer fully counter-clockwise, press the start button. The drive DC power light should come on; the motor should not rotate. Press the stop button; the DC power indicator should go out. Press the start button again and slowly increase the speed potentiometer to maximum, observing that the motor speed increases smoothly to maximum.

WARNING

IF THE MOTOR RUNS AWAY, STOP THE DRIVE IMMEDIATELY. CHECK THE TACHOMETER FEEDBACK CONNECTIONS, POLARITY, AND PROGRAM JUMPERS.

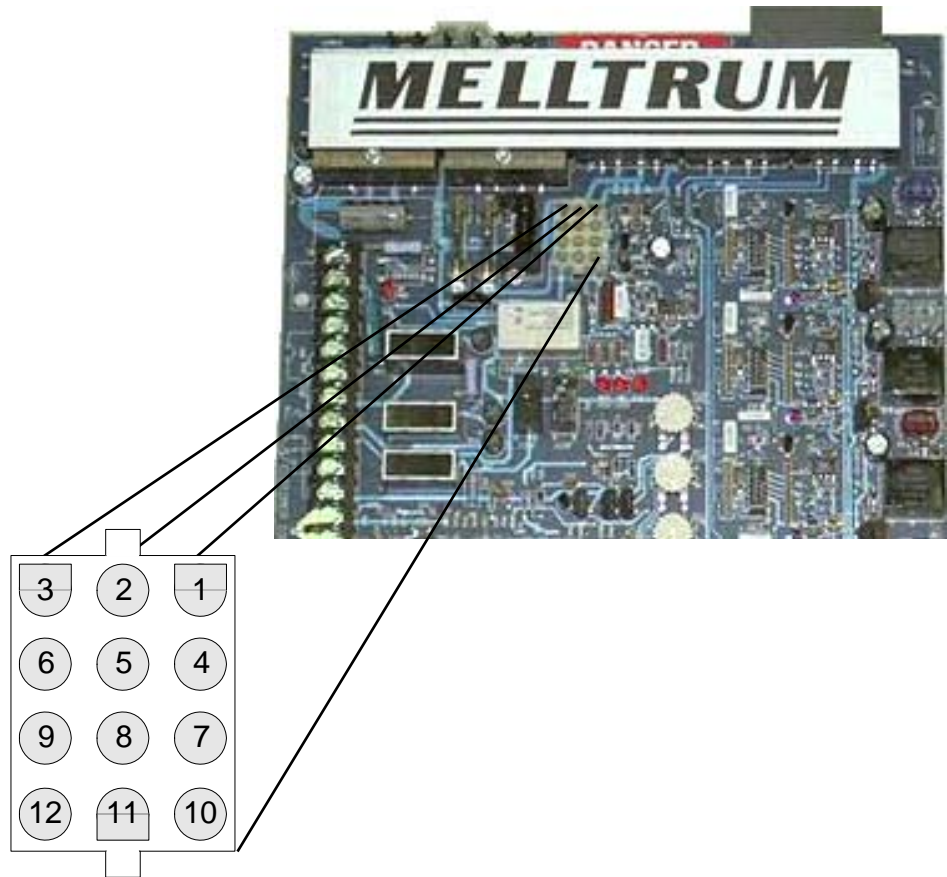

LEAD (+)	CONNECTION (-)	READING (VOLTS)
1	2	Line to line Voltage L1-L3
2	7	Line to line Voltage L3-L2
3	5	+ 15 Volts DC
4	5	Output Velocity Error Amplifier (1-1.5 V)
5	-	Signal Common
6	-	Signal Common
7	1	Line to Line Voltage L1-L2
8	5	Shunt Voltage (-1VDC @ 100% current)
9	12	Control Voltage, 115 VAC Loaded, 150 VAC Unloaded
10	5	Output Current Error Amplifier (0 to -11.5V)
11	5	- 15 VDC

Figure 15: Test Points at J3

NOTE
THIS CONNECTOR IS NORMALLY USED FOR OPTIONAL TEST METER.

3.10 ADJUSTMENTS

Max Speed

The operator controlled speed potentiometer should be fully clockwise when adjusting the maximum speed (Clockwise increases speed). The maximum speed is typically adjusted for maximum rate armature voltage output to the motor.

Min Speed

The operator's speed potentiometer should be fully counter-clockwise when adjusting the minimum speed. When a speed of zero is desired, the minimum speed should be adjusted fully counter-clockwise. The minimum speed adjustment does not affect maximum speed.

Stability

A mid position setting will give optimum results for most machine load applications. Clockwise rotation will increase response. Counter-clockwise rotation will dampen the response.

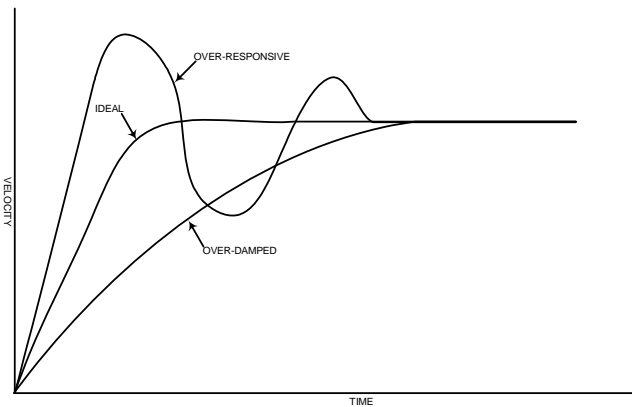

Figure 16: Stability Effects of the Velocity Profile

Jog

If the jog push-button is connected, the jog adjustment sets the preset slow speed. The jog speed is a "stepped" input reference from 0 to 30% of maximum speed.

Current Limit

The scaled potentiometer dial indicator is used to make this adjustment. The recommended setting is 100%. Adjust the potentiometer clockwise to increase allowable armature current.

Accel Time

Clockwise adjustment increases the time that the drive takes to accelerate to the set speed. This rate of change is linear (or constant) throughout the speed range (the maximum acceleration rate may be limited by the current limit setting).

Decel Time

Clockwise adjustment causes the drive to decelerate more slowly. The drive cannot decelerate the motor more quickly than the coast rate.

Phase Balance Adjustments

NOTE

THE PHASE ADJUSTMENTS ARE FACTORY SET AND NORMALLY WILL NOT NEED ANY FURTHER ADJUSTING.

1. Note current limit setting and rotate pot fully counter-clock-wise.
2. With drive in run mode, adjust each phase balance LED until it just lights.
3. Reset current limit pot to original setting and check phase balance under load. Advance adjustment only to balance a low pulse, so that LEDs will remain on as Steps 1 and 2 require.

IR Compensation

IR Compensation increases the drive speed reference signal as armature current increases. An increased voltage drop, due to the internal resistance of the motor, is a result of the increase in current. This increased voltage drop causes a decrease in motor speed. IR COMP can be used to compensate for this decrease in motor speed during loaded conditions, therefore improving speed regulation without speed feedback. This adjustment is only used if armature feedback is used (set fully counter-clockwise for tachometer feedback).

Procedure

1. Run motor at maximum speed with no load.
2. Record the motor RPM (hand tachometer required).
3. Load the motor.
4. Again measure the motor RPM. Match this "loaded" speed to the unloaded speed of Step 1 using the IR Comp potentiometer.
5. Repeat Steps 1 through 4.

NOTE

EXCESSIVE IR COMPENSATION CAN CAUSE THE DRIVE CONTROL TO BECOME UNSTABLE.

SECTION 4 MAINTENANCE AND TROUBLE SHOOTING

4.1 NORMAL MAINTENANCE

No adjustments should be necessary on the **MELLTRUM** Drive. Only standard maintenance procedures need to be followed. In addition, some common sense maintenance needs to be followed.

- **KEEP IT CLEAN:** The control should be kept free of dust, dirt, oil, caustic atmosphere and excessive moisture. External cabinet filters should be checked and cleaned periodically. Do not use high pressure air to blow the control or cabinet clean--use a small brush and vacuum cleaner to limit dust being stirred up during cleaning.
- **KEEP IT COOL:** The control should be located away from machines having a high ambient temperature. Air flow across heatsinks must not be restricted by other equipment within the enclosure.
- **KEEP CONNECTIONS TIGHT:** The equipment should be kept away from high vibration areas that could loosen connections or cause chafing of wires. All interconnections should be re-tightened at time of initial start-up and at least every six months.
- **FOLLOW MOTOR MAINTENANCE INSTRUCTIONS:** The brushes and commutator should be inspected for excessive wear or arcing. Motor wiring should be inspected for wear and the connections should be checked for tightness. For more detail, consult the instructions supplied with the motor.

WARNING

THE DC MOTOR MAY BE AT LINE VOLTAGE EVEN WHEN IT IS NOT IN OPERATION. THEREFORE, NEVER ATTEMPT TO INSPECT, TOUCH OR REMOVE ANY INTERNAL PART OF THE DC MOTOR (SUCH AS THE BRUSHES) WITHOUT FIRST MAKING SURE THAT ALL AC POWER TO THE CONTROL AS WELL AS THE DC POWER TO THE MOTOR HAS BEEN DISCONNECTED.

4.2 GENERAL TROUBLESHOOTING

- The most frequent causes of drive failure are:
- A broken wire or loose connection.
- Circuit grounding within the interconnections or the power wiring.
- Mechanical failure at the motor, or tachometer.
- Do **NOT** make adjustments or replace components before checking all wiring. Check all indicator lights before proceeding with troubleshooting checks.

WARNING

TEST EQUIPMENT USED SHOULD NOT HAVE ITS CHASSIS GROUNDED BY THE THIRD PRONG OF THE POWER PLUG OR INCIDENTAL CONTACT TO THE POWER PLUG OR INCIDENTAL CONTACT OF ITS CHASSIS TO A GROUNDED OBJECT. WITH TEST EQUIPMENT NOT GROUNDED, THE CHASSIS MAY BE AT HIGH VOLTAGE. EXTREME CARE SHOULD BE TAKEN WHEN OPERATING THIS EQUIPMENT TO AVOID SERIOUS ELECTRICAL SHOCK.

Modern solid state electronic circuitry is highly reliable. Often problems which appear to be electrical are in fact mechanical. Motor maintenance should be kept up and checked in the event of any drive problems. Refer to motor owners manual for maintenance and repair procedures.

4.3 SYMPTOMS AND CAUSES

Drive Does Not Run

- Fuses blown
- Armature contactor not energized or defective
- Faulty control logic wiring
- Motor or machine jammed
- Defective speed potentiometer or wiring
- Control in fault trip
- Open armature or field circuit
- Incorrect jumper programming (refer to 3.5)
- Open motor thermal switch
- Blower motor not energized

Drive Runs To Top Speed

- Faulty Tachometer or Tachometer wiring
- Defective speed potentiometer or wiring
- Incorrect feedback jumper programming
- Open or incorrectly wired field circuit

Speed Varies

- Drive in current limit
- Motor being driven by external forces
- Low line voltage
- Stray pick-up in signal wiring (refer to 3.4.3)
- Defective tachometer or coupling
- Worn motor brushes
- Incorrect IR or stability adjustment (see 3.10)
- Incorrect shunt resistor (refer to 3.6)

Drive Trips Out

- Intermittent open in control wiring logic
- Fault trip condition exists:
 1. DC overload
 2. Field loss
 3. Abnormal motor loading
 4. Faulty motor
 5. Poor drive control ventilation
 6. Accel rate too quick (refer to 3.10)
 7. Defective SCR
 8. Incorrect shunt resistor (refer to 3.6)

Motor Will Not Reach Top Speed

- Incorrect speed potentiometer (use only a 2K ohms, 2 watt potentiometer)
- Incorrect field current or wiring (noted by current limit LED)
- Motor overloaded (noted by current limit LED)
- Incorrect current limit setting (refer to 3.10)
- Incorrect max speed adjustment (refer to 3.10)
- Incorrect shunt resistor (refer to 3.6)
- Low line voltage
- Blow line fuses

Line Fuses Blown

- Shorted armature
- Ground fault
- Shorted SCR
- Defective control circuit board

4.4 MELLTRUM 1 SCR REPLACEMENT

Tools

- 5/16" Nut Driver
- 7/16" Nut Driver
- Medium Screwdriver
- Torque Wrench

Read all instructions carefully before beginning.
Refer to **MELLTRUM 1** Chassis Diagram.

Procedure:

1. Remove the armature fuse (4FU). Also remove the two nuts from the stud that the top end of this fuse rests on.
2. Remove the hardware from the A+ stud.
3. Remove the six (6) SCR hold down screws.
4. Swing the circuit board out of the chassis.
5. Replace defective SCRs wire for wire.
6. Sparingly apply a silicon thermal compound to the bottom of the new SCR.
7. Replace the circuit board. Torque SCR hold down screws to 19-inch pounds. Replace other hardware.

4.5 MELLTRUM 2, 2+, 3, 4 and 4+ SCR REPLACEMENT

Tools

- 3/8 " Nut Driver
- Screwdriver (medium)
- Torque Wrench

Read instructions completely before beginning.

1. Mechanically disconnect the MC relay by removing the single hold-down screw. Do not remove the electrical connections.
2. Remove both buss bars by unbolting the three connecting bolts on each.
3. Mechanically disconnect the SCR module, to be replaced, by removing the two hold-down bolts (one each at the top and bottom). Remove only the AC line electrical connections from the SCR at this time.

4. Sparingly apply a silicon thermal compound to the bottom of the new SCR.
5. Bolt the new SCR in place keeping the gate connections (G1 and G2) close to the interconnect board.
6. Torque the hold-down bolts to 19 inch-pounds.
7. Transfer electrical connections from the used SCR to the new SCR one at a time to prevent connection errors.
8. Install buss bars.
9. Mount MC relay



SCR PACKAGES

Figure 17: The Interconnect Board



Figure 18: MC Relay



Figure 19: Dual Package SCR

SECTION 5
SCHEMATICS

NOTICE: This drawing is furnished for reference only. Reproduction thereof, does not convey any manufacturing rights.

MOTOR SPEED CONTROL KIT
MOTOR CONTROL P.C. BOARD 222-1000
05177-06

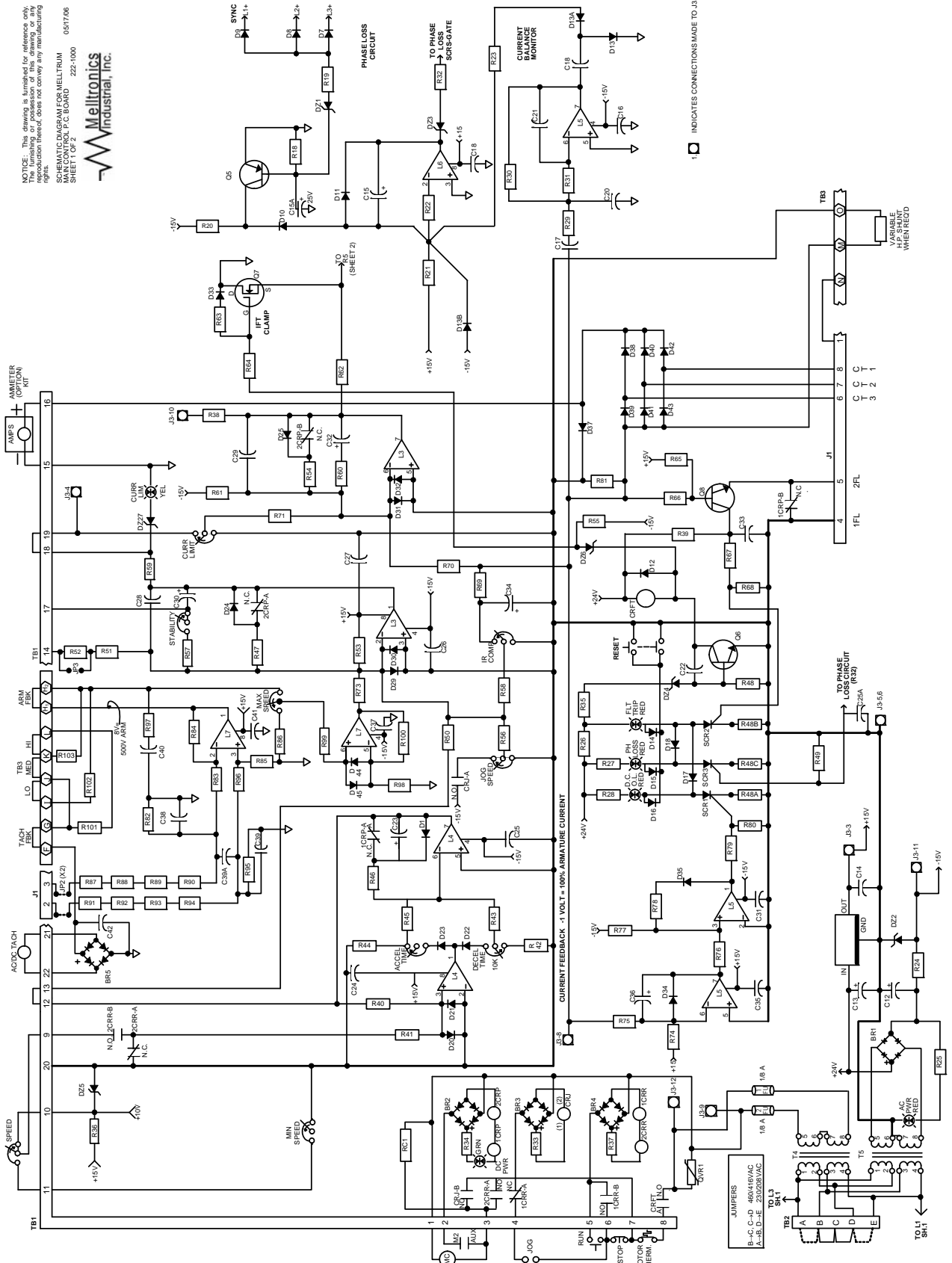

Figure 20: Schematic Diagram - Main Control, Sheet 1

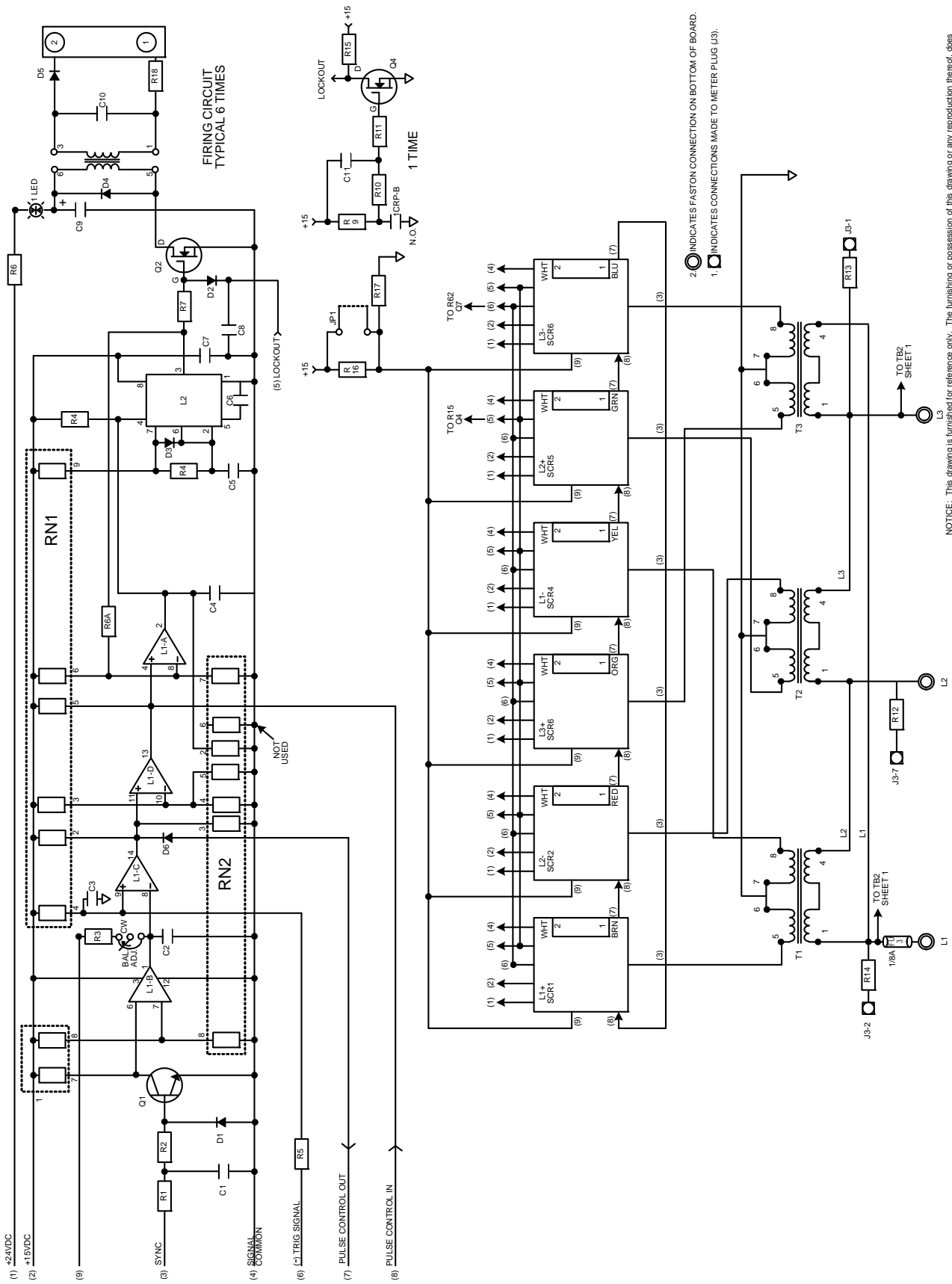

Figure 21: Schematic Diagram - Main Control, Sheet 2

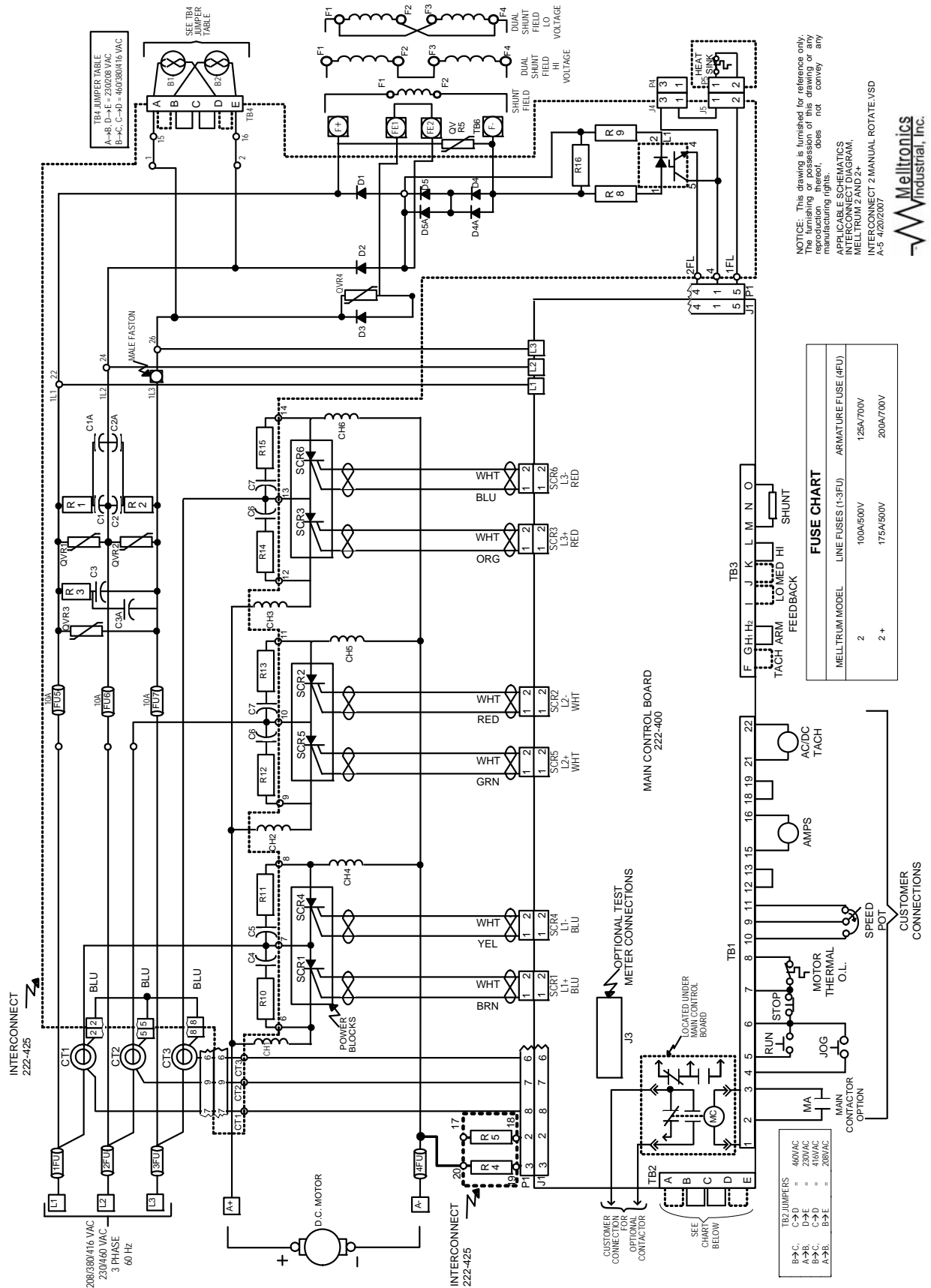

Figure 24: Interconnect Diagram - **MELLTRUM 2 & 2+**

NOTICE: This drawing is furnished for reference only. The furnishing or possession of this drawing or any reproduction hereof, does not convey any rights in the intellectual property of Melltronics Industrial, Inc. APPLICATION SCHEMATICS INTERCONNECT DIAGRAM, MELLTRUM 2 AND 2+, INTERCONNECT 2 MANUAL ROTATE.VSD A-5 4/20/2007



FUSE CHART		
MELLTRUM MODEL	LINE FUSES (1-3FU)	ARMATURE FUSE (4FU)
2	100A/500V	125A/700V
2 +	175A/500V	200A/700V

TB2 JUMPERS	
B → C	= 460VAC
C → D	= 230VAC
A → B	= 208VAC
D → E	= 208VAC
A → E	= 208VAC

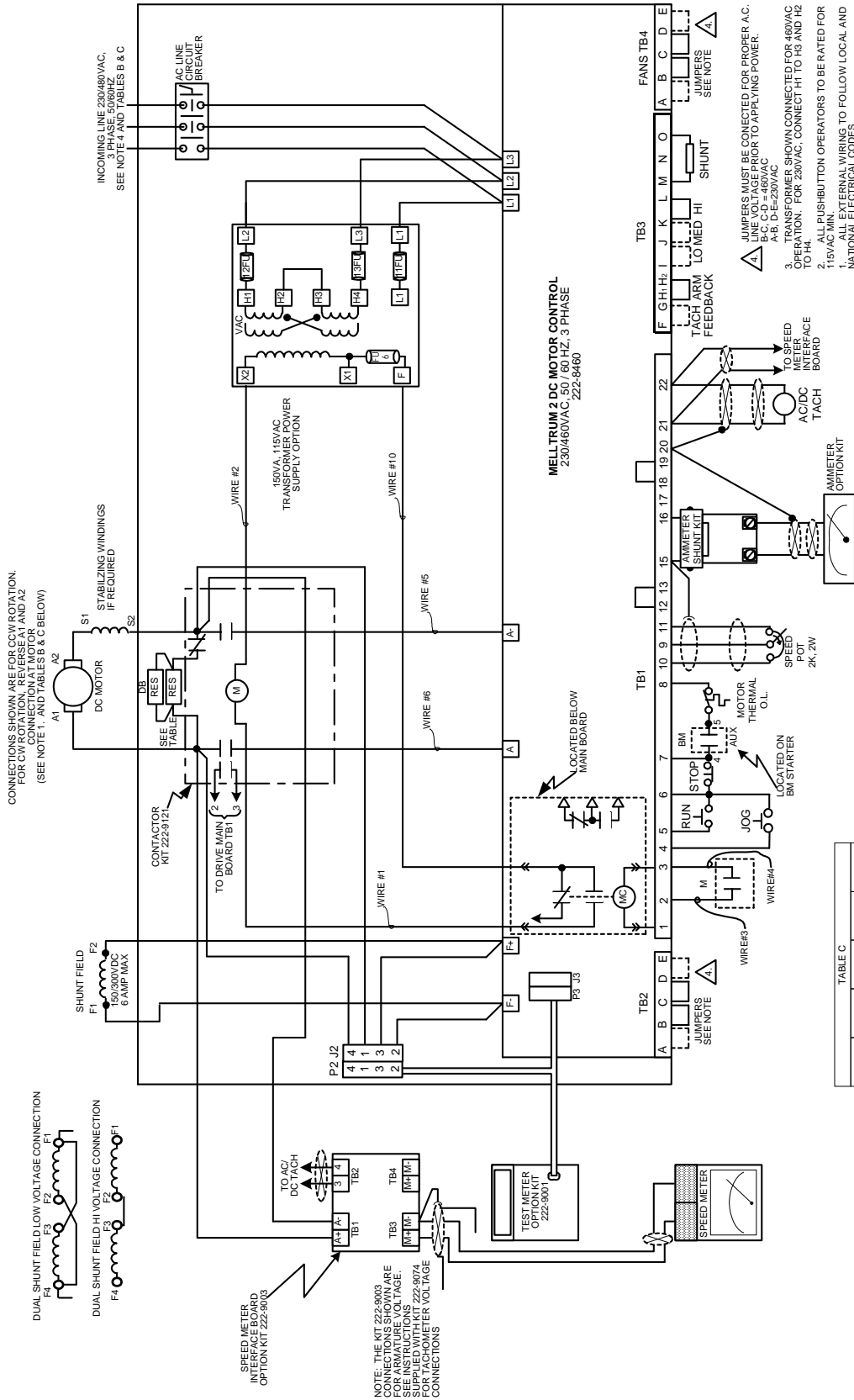

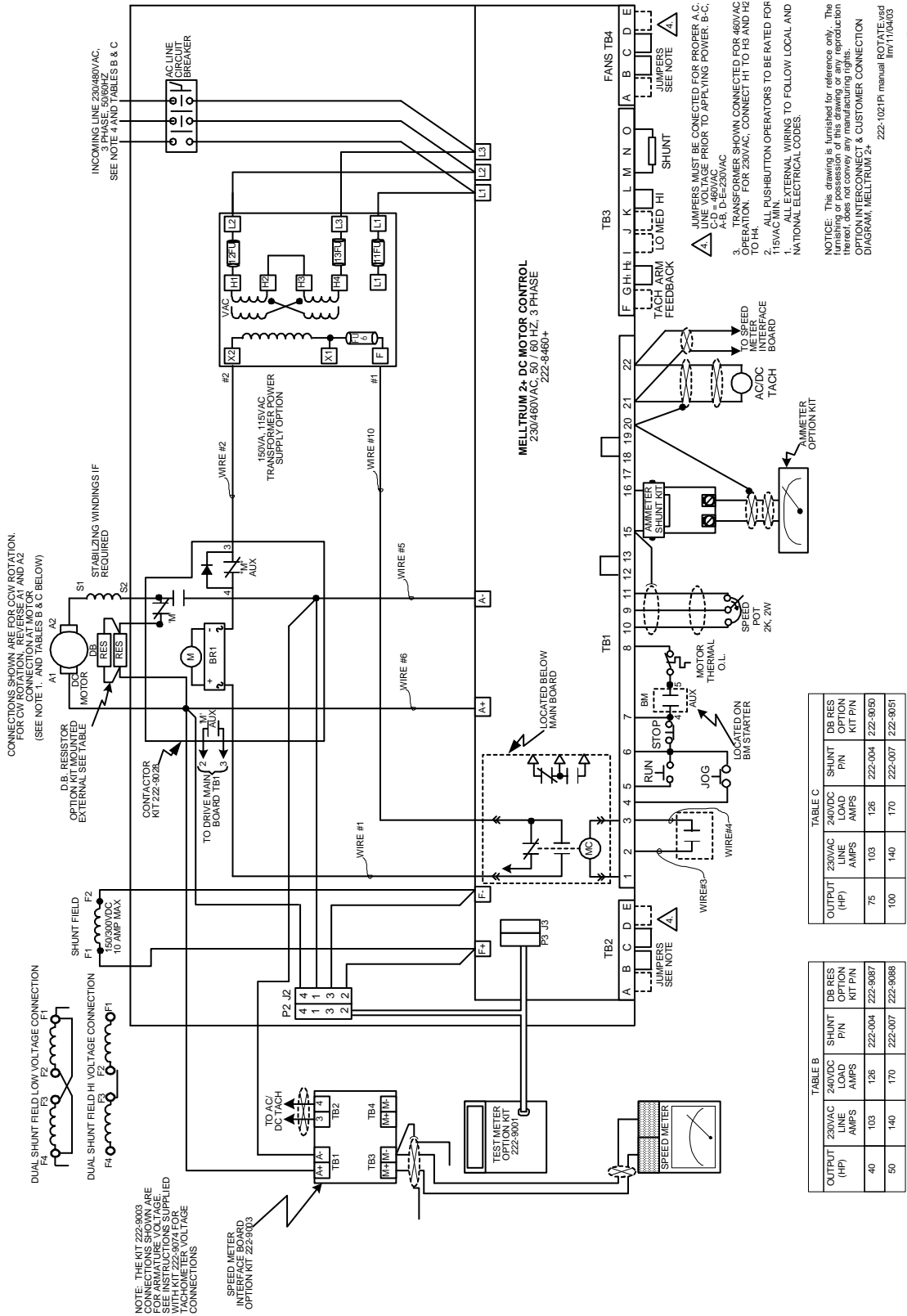

Figure 26: Option Interconnect & Customer Connection Diagram - **MELLTRUM 2+**



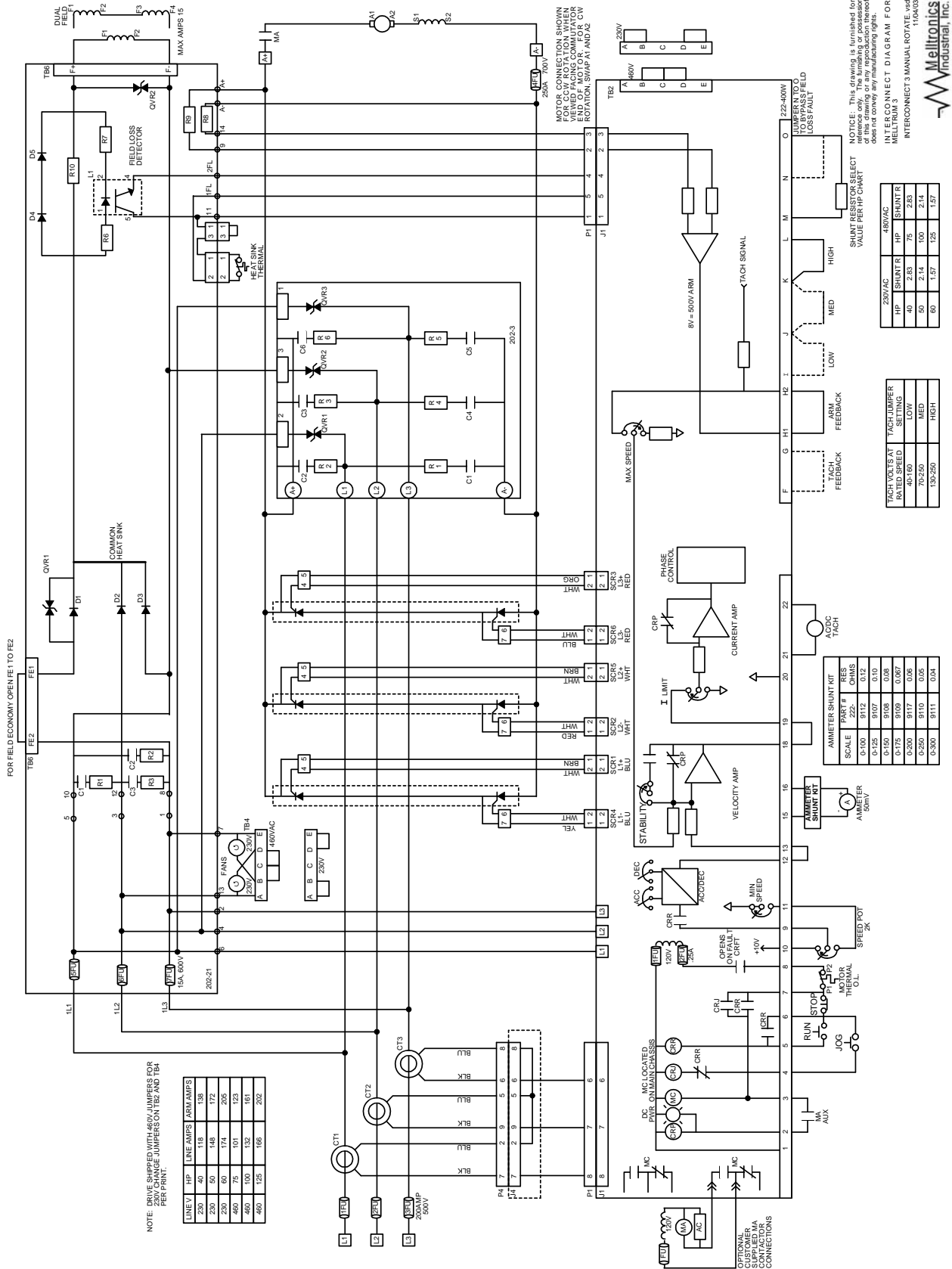

Figure 27: Interconnect Diagram – MELLTRUM 3

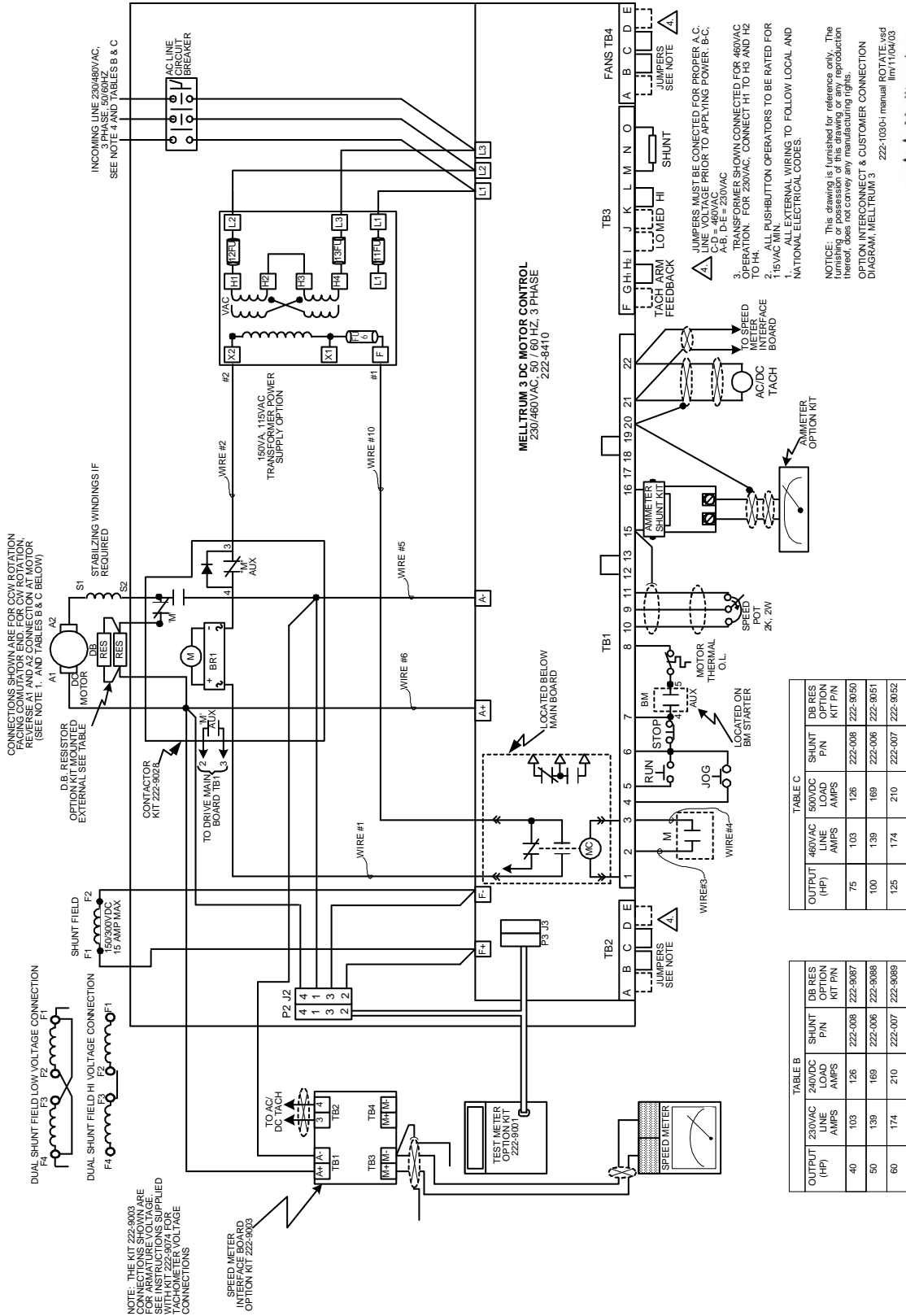

Figure 28: Optional Interconnect & Customer Connection Diagram - **MELLTRUM 3**



NOTICE: This drawing is furnished for reference only. The user assumes all responsibility for the production thereof and does not convey any manufacturing rights. OPTION INTERCONNECT & CUSTOMER CONNECTION DIAGRAM, MELLTRUM 3 222-1030-1 manual ROTATE.vsd ltr11/04/03

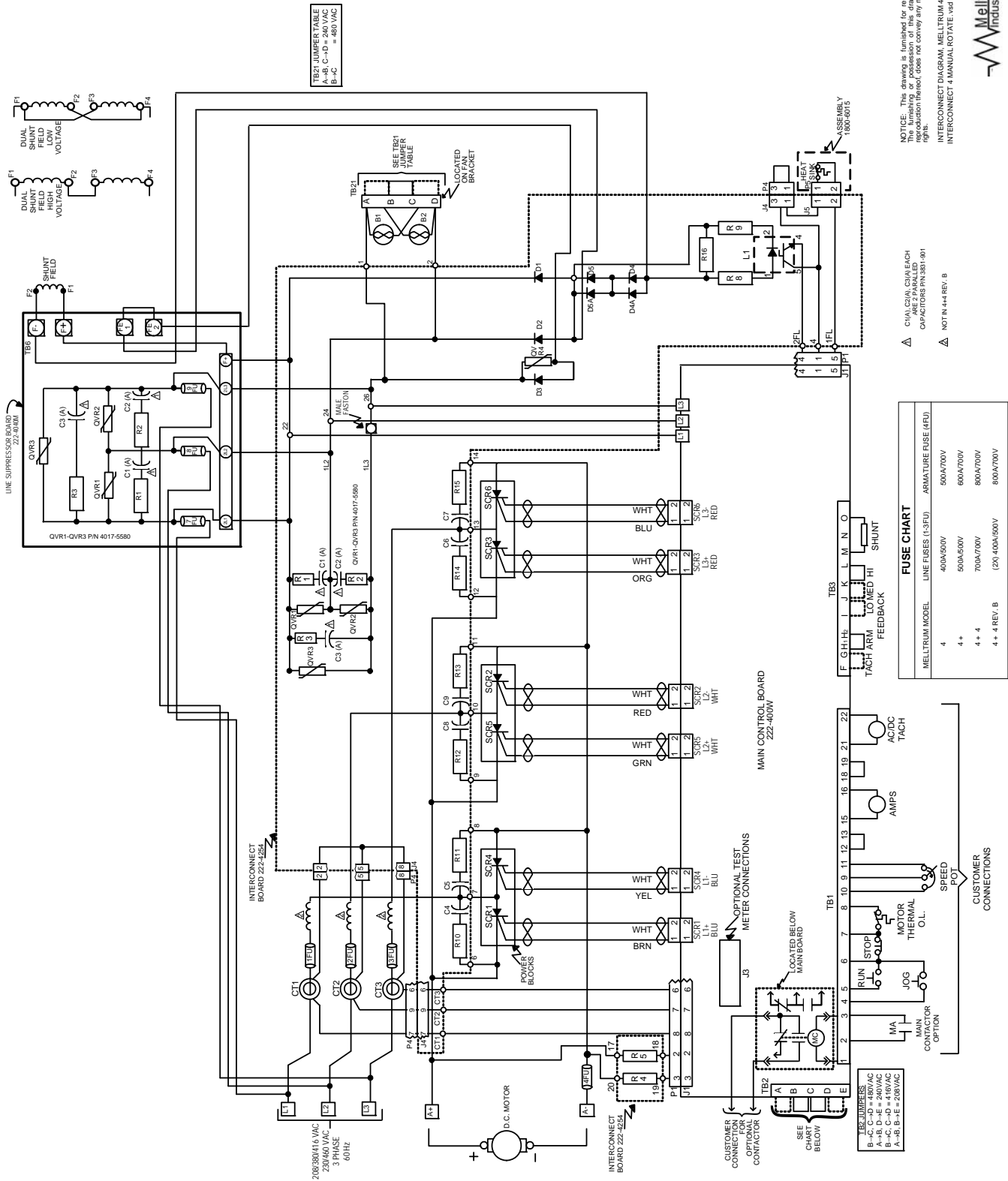

Figure 29: Interconnect Diagram - **MELLTRUM 4, 4+ AND 4+4**

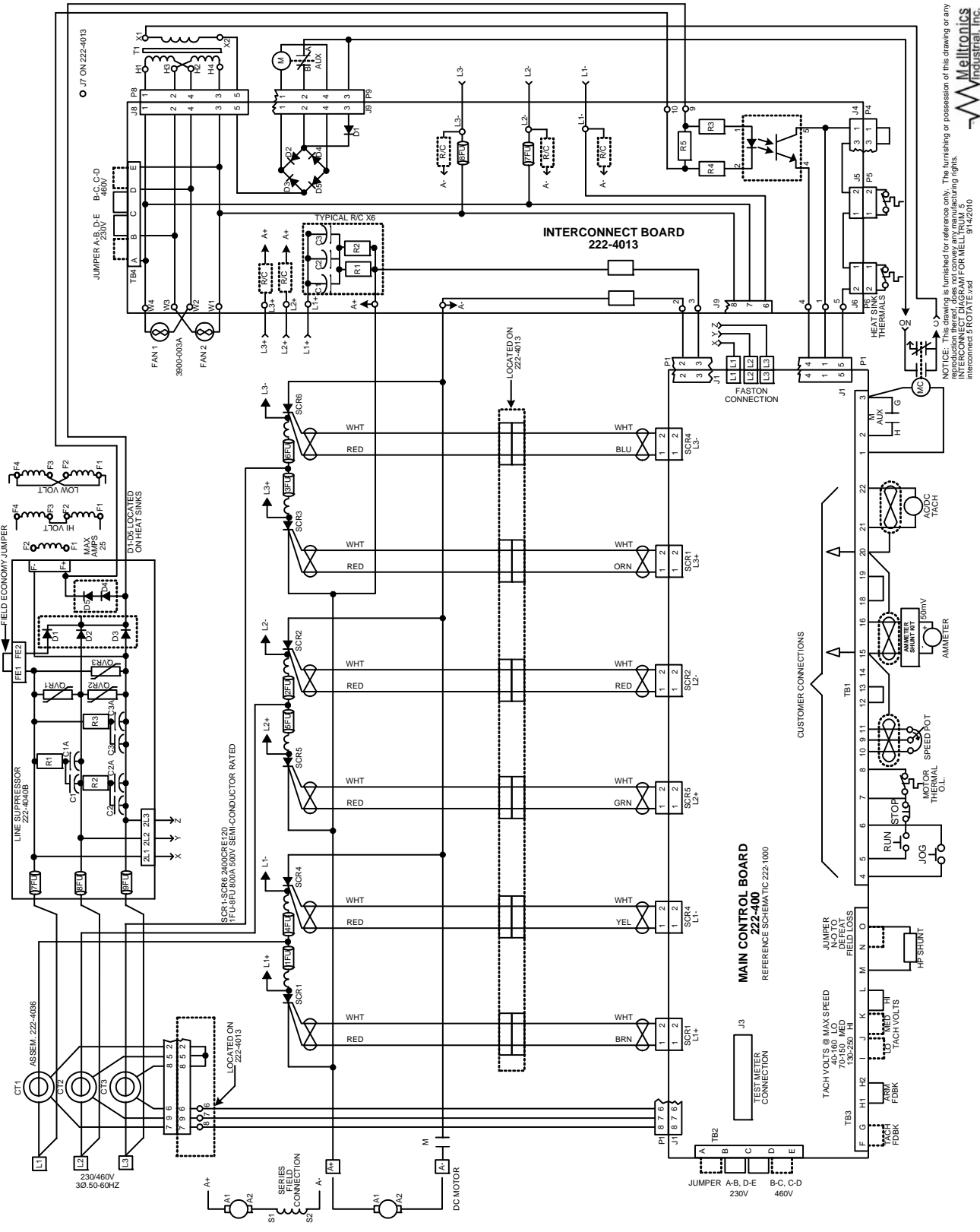

Figure 31: Interconnect Diagram – MELLTRUM 5

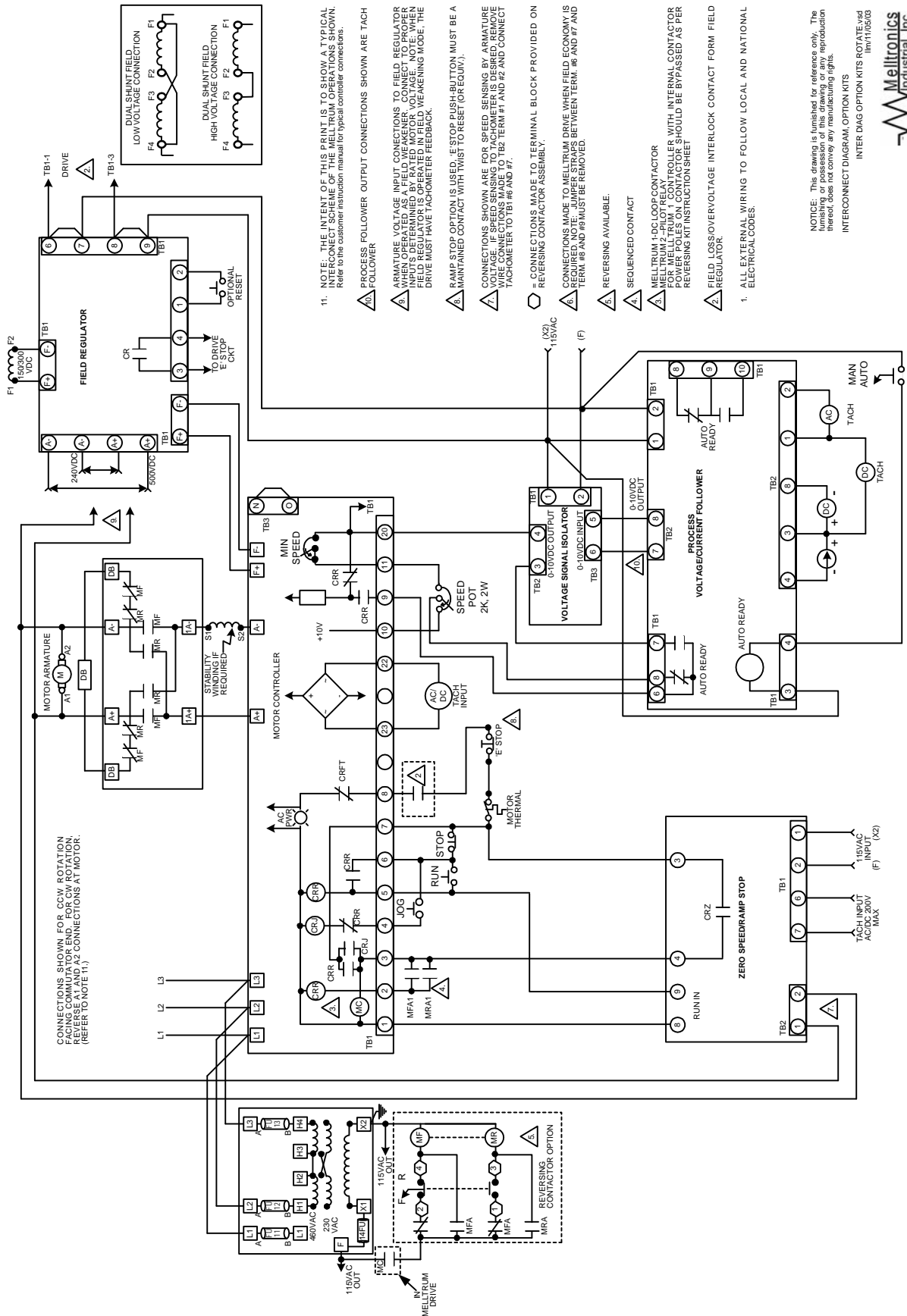

Figure 32: Interconnect Diagram, Option Kits

**SECTION 6
PARTS AND OPTION KITS**

MELLTRUM SPARE PARTS AND KITS			
PART #	DESCRIPTION	PART #	DESCRIPTION
222-400	MELLTRUM 1 ,2, 2+, 5 TOP BOARD	222-9030	MELLTRUM 4+4 Armature Contactor
222-400W	MELLTRUM 3, 4, 4+, 4+4 WIDE TOP BOARD	222-9064	MELLTRUM Process Signal Follower**
222-431	MELLTRUM 1 LOWER BOARD	222-9065	MELLTRUM Voltage Signal Isolator**
222-425	MELLTRUM 2 LOWER BOARD	222-9066	MELLTRUM Field Regulator**^
222-425+	MELLTRUM 2+ LOWER BOARD	222-9068	MELLTRUM Zero Speed/Ramp Stop**
222-4035	MELLTRUM 3 FIELD SNUBBER	222-9074	MELLTRUM Speed Meter
222-4254	MELLTRUM 4 LOWER BOARD	222-9101	MELLTRUM 1 & 2 Reversing **
222-4040M	MELLTRUM 4 LINE SNUBBER	222-9120	MELLTRUM 150VA Control Transformer
222-4040A	MELLTRONICS 'SPEC4'REPLACEMENT LINE SNUBBER	222-9121	MELLTRUM 2 Contactor **
222-9001	MELLTRUM Test Meter	232-9135	MELLTRUM Stand Alone Field Regulator^
222-9003	MELLTRUM Speed Meter Interface	222-90XX & 91XX	MELLTRUM Dynamic Braking Resistors
222-9028	MELLTRUM 2+ and 3 Armature Contactor**	222-91XX	MELLTRUM Ammeter Shunt
222-9029	MELLTRUM 4 & 4+ Armature Contactor **	222-9201	MELLTRUM Field Economy
		Option	MELLTRUM 1, 2, 2+, 3, 4 & 4+ at 208V/416V or 380V

*Notes: ** The 150VA, 115VAC control transformer (222-9120) is required.
^ The motor nameplate speed rating must be sufficient for extended speed operation to use this option.*

This is a partial listing. MELLTRONICS is able to supply all MELLTRUM drive parts.

REVISION TABLE

REV	DATE	DESCRIPTION	REVISIONS
NONE	08/20/2003	1 ST RELEASE BY MELLTRONICS	NONE
A	11/13/2003	2 ND RELEASE BY MELLTRONICS	FIGS: 20-32, TEXT ERRORS, SCR REF REMOVED
B	03/08/2004	3 RD RELEASE BY MELLTRONICS	FIGS: 1-4, 6-9, 11-14, 16, 29
C	02/17/2005	4 TH RELEASE BY MELLTRONICS	PG. 6, 5, 13, 18, 29, 31, 33
D	10/12/2005	5 TH RELEASE BY MELLTRONICS	FIGS: 29, 30 DWG ERRORS 4+4 REV. A ADDED
E	09/13/2006	6 TH RELEASE BY MELLTRONICS	FIGS: 2, 15, 20, 21, 24, 29, 31 PG. 6, 17, 18
F	4/20/2007	7 TH RELEASE BY MELLTRONICS	FIG. 24, FIG. 29
G	9/15/2010	8 TH RELEASE BY MELLTRONICS	FIG. 22, FIG. 27, FIG. 31 PG. 21

SECTION 7 WARRANTY

MELLTRONICS warrants to the Buyer whom purchases for use and not for resale that the equipment described in this instruction manual is sold in accordance with published specifications or the specifications agreed to in writing at the time of sale. Melltronics further warrants that such goods are free of defects in material and workmanship.

The warranty shall apply for a period of twelve months (12) from date of purchase, not to exceed eighteen months (18) from the date of manufacture.

If the goods fail to perform to Melltronics specifications as outlined in the warranty, then Buyer should contact Melltronics to obtain a "Material Return Authorization" (MRA), prepare the goods for shipment and return the goods to Melltronics for repair or replacement at Melltronics option. Buyer will bear all costs of transportation to and from Melltronics factory, risk of loss for goods not at Melltronics factory and any cost required to remove or prepare the goods for shipment to the repair facility, and to reinstall equipment subsequent to repair.

This warranty is effective only if written notification of any claim under this warranty is received by Melltronics at the address indicated below within thirty-days (30) from recognition of defect by Buyer.

The above indicates the full extent of Melltronics liability under this warranty. Melltronics specifically disclaims any liability for: (a) damage or failure due to improper use or installation; (b) damages in shipment; (c) damage or failure due to abnormal operation conditions of load, temperature, altitude or atmosphere whether intentional or unintentional; (d) non-authorized service, repair, modification, inspection, removal, transportation or installation; (e) misapplication or misuse, or; (f) consequential damages arising out of the use, operation or maintenance of the goods.

THERE ARE NO OTHER WARRANTIES, EXPRESSED OR IMPLIED, WHICH EXTEND BEYOND THAT DESCRIBED HEREIN. MELLTRONICS SPECIFICALLY DISCLAIMS ANY IMPLIED WARRANTY OF MERCHANTABILITY OF GOODS OR OF THE FITNESS OF THE GOODS FOR ANY PURPOSE.

Melltronics neither assumes nor authorizes any representative or any other person to assume for Melltronics any other liability in connection with the sale or any shipment of Melltronics goods. Melltronics reserves the right to make changes and improvements in Melltronics goods without incurring any obligation to similarly alter goods previously purchased.



MAIL: PO BOX 2368
INDIAN TRAIL, NC 28079-2368
SHIPPING: 3479 GRIBBLE ROAD
MATTHEWS, NC 28104-8114

PHONE: 704-821-6651
www.melltronics.com